

# **FuRIOUS 2**

*"The Fieldbus is ready  
for practical use"*

**Excerpt**

# FuRIOS 2

---

## Fieldbus and Remote I/O System Comparison

### Preface

*Prof. Dr.-Ing. Birgit Vogel-Heuser,  
Institute of Automation Technology / Process Informatics  
at Bergische University Wuppertal*

### Preface to second, updated edition

*Prof. Dr.-Ing. habil. Lothar Litz  
Institute of Automation Technology  
Technical University Kaiserslautern*



### FuRIOS: Fieldbus and Remote I/O – a system comparison

Published in atp – Automatisierungstechnische Praxis 44 (2002),  
Edition 12/2002, pages 61 - 70

*Dr.-Ing. Thomas Tauchnitz, Aventis Pharma Deutschland GmbH  
Dipl.-Ing. Wilfried Schmieder, Aventis Pharma Deutschland GmbH  
Dipl.-Ing. Sven Seintsch, Infraser v GmbH & Co Höchst KG*

### Fieldbus and Remote I/O: System Comparison „FuRIOS“

Presentation at the NAMUR general assembly, 08.11.2002

*Dr.-Ing. Thomas Tauchnitz, Aventis Pharma Deutschland GmbH*

### Fieldbus Experience Reports

Presentation at the NAMUR general assembly, 04.11.2004

*Martin Schwibach, BASF  
Thomas Meier-Künzig, DSM  
Sven Seintsch, infraser v höchst technik  
Dr. Joachim Zobel, Novartis*



### Push-button telephones were the first step on the way to the mobile phone

Interview mit

*Dr.-Ing. Thomas Tauchnitz, Aventis Pharma Deutschland GmbH  
Manfred Dietz, Infraser v GmbH & Co Höchst KG*

### Savings are not the goal of fieldbus

Interview with

*Frans van Laak, Speaker of NAMUR working group 2.6 „Fieldbusses“  
Harry van Rijt, DSM TechnoPartners*

### From theorie to practical use

Aventis applies FuRIOS study in real pharmaceutical plant  
Round Table with project participants



## Opinions

“In the meantime the advantages of the technology are undisputed”

*Dr. Oestreich, Managing Director Profibus Nutzerorganisation*

“A manufacturer can obtain enormous benefits from this technology”

*Richard Timoney, President Fieldbus Foundation*

“Fieldbus technology is mature enough for practical use”

*Martin Schwibach, BASF, Speaker of NAMUR AK 2.6 „Fieldbusses“*

“Already today, users are clearly deciding in favour of fieldbus”

*Marc Van Pelt, Vice President Europe Fieldbus Foundation*

“With fieldbus, we have got all this marvellous information with its huge potential”

*Ian Verhappen, Chairman Fieldbus Foundation Enduser Advisory Council*

“Things are looking good for fieldbus”

*Dr. Joachim Zobel, Senior Automation Engineer Novartis Pharma*



## Fieldbus is getting its wings

Published in MessTec & Automation 12/2004, page 62 - 64

*Dr. Christine Eckert, journalist*



## Fit for the future

Fieldbus technology at Clariant

Published in CHEManager Edition 7, April 2005

*Dipl.-Ing. Michael Pelz, Clariant GmbH*

*Dipl.-Ing. Thomas Eichhorn, Clariant GmbH*



## The applicability of the FuRIOS Study

Published in atp – Automatisierungstechnische Praxis 45 (2003),

Edition 3/2003, pages 51 - 54

*Dipl.-Wirtsch.-Ing. Thomas Kasten, Pepperl+Fuchs GmbH*

## Less handicaps in explosion hazardous areas

Published in P&A Magazine Edition 1, March 2005

*Dipl.-Wirtsch.-Ing. Thomas Kasten, Pepperl+Fuchs GmbH*



## High-Power Trunk Concepts –

with FieldConnex® Fieldbus Installation Technology



Presented with the kindest greetings from:

**Pepperl+Fuchs GmbH**

[www.fieldconnex.info](http://www.fieldconnex.info)



## Preface to second edition

# The break-through of Fieldbus in Process Automation – do we see it now?

The possibility of technical realization has been proven for some time now: Fieldbus based solutions for automation of process production plants in explosion hazardous areas. We all know that a break-through does not automatically and immediately follow the technical realization. It took almost 10 years from the first Process Control System in a pilot plant to its routine operation. The break-through was somewhere in-between. How long is this way for Fieldbus and where are we today on this way? The first test and laboratory installations of fieldbus have been long ago. The first production plants are in operation now, several more are being commissioned today. Even more are in the design stage. Do we see the break-through? It certainly looks this way.

The right evaluation at the right time: FuRIOS (Fieldbus and Remote I/O System Comparison). Nine manufacturers participated in this study which was conducted under the lead of an user company. It was the right time for this study since, with fieldbus barriers, segment couplers and valve boxes, it was able to include the latest technical developments. Without these the comparison of economic efficiency would have been in favour of Remote I/O. Similarly FuRIOS was the right study since it asks and answers all essential questions in a very methodical way. The manifold advantages of Fieldbus over Remote I/O are described in all details. Especially one important condition got not forgotten in FuRIOS: The long-term availability of the new technology. In terms of investment protection this is essential for production plants since – typically for process industry – they are in operation for at least 25 years. Ultimately long-term availability is one of the major differences to Fieldbus in factory automation, were the break-through took place during a few years only, and this was several years ago. Studies like FuRIOS are essential milestones on the way to break-through. It finally takes place when people do not write about it any more, but when the acceptance is proven by the increasing number of fieldbus-based plants. The principle of positive feedback, known to every process control engineer, will help. Any break-through profits from feedback, without it a break-through is hardly possible. A major argument for an investment decision is the economic efficiency. Lower investment costs for a new technology lead, due to economies of scales, to a price decrease and therefore to further reduction of investment costs. Each new plant working on fieldbus is part of the proof of acceptance and therefore an important step on this way. Each one of these plants is a part of the break-through, which we indeed see today.

*Prof. Dr. Ing. habil. Lothar Litz*  
*Institute of Automation Technology*  
*Technical University Kaiserslautern*

*March 2005*



# FuRIOS: Fieldbus and Remote I/O – a system comparison

Wilfried Schmieder und Thomas Tauchnitz, Aventis Pharma  
and Sven Seintsch, Infraseriv GmbH

Translation of the german article "FuRIOS: Feldbus und Remote I/O – ein Systemvergleich", originally published in atp Automatisierungstechnische Praxis 44 (2002), Edition 12, pages 61-70

*In contrast to the Remote I/O systems, which have reached a wide market penetration within few years, the technically superior Fieldbus does not see a market breakthrough yet. It is frequently said that the Remote I/O system achieves almost all advantages compared to the conventional cabling of field instruments so that the move towards Fieldbus does not pay any more. On the other hand Remote I/O systems are often seen as interim solution. In order to help clarify this contradiction the companies Aventis and Infraseriv performed a system comparison of Remote I/O and fieldbus in cooperation with the IGR (Industrial Practices Interest Group, see [www.igrtechnik.com](http://www.igrtechnik.com)) and several instrument manufacturers. The project name FuRIOS (Fieldbus and Remote I/O – System comparison), in German language associating "race", might provoke exaggerated expectations. The result, however, is that the Fieldbus is superior to Remote I/O in many aspects: It brings further savings in investments, accelerates project execution and startup and so provides the migration to a new technological platform that enables the development of innovative and attractive instruments. Manufacturers and users are encouraged to make intelligent use of these new opportunities and do more than just transfer the conventional instruments and operations without modifications to the Fieldbus.*

## 1. Introduction

Mature Remote I/O systems have been on the market for several years. Many companies have made extensive use of this technology in new production plants, allowing it to prove its worth in extremely large and complex applications. It has demonstrated that it is a "feasible method", see (1). The cost savings in comparison to conventional wiring using field distributors, multicore cables and patch cabinets are huge. Certain disadvantages, such as in the plant-specific structure, in physical location within the plant, a more complex configuration and additional training requirements, are accepted.

The situation relating to fieldbus in the processing industry is entirely different. For many years, the competition between several fieldbus standards only confused equip-

ment manufacturers and users. In addition, there were technical problems and bottlenecks. However, since the international standardisation came to a temporary finish with the ratification of IEC 61158 (2) and with Profibus PA and Foundation Fieldbus two systems are now on offer for the processing industry, the technical base for the use of the fieldbus is now given. There is a large offering of fieldbus-capable devices, while certification centres offer their services.

In a technological sense, fieldbus is one generation ahead of Remote I/O systems. The field signals can be transmitted digitally, in the same format as they exist in the field device anyway. The elaborate and often fault-risky conversion into an analogue signal and back again is no longer necessary. Diagnosis data can be transmitted without difficulty along with the measurement signal and need not to be encrypt-

ed into the signal, like when using the HART protocol. The standardisation means that many signals are coded in the same way in all devices, so that they are available in a standard form without requiring any specific decoding for individual devices. Measurement devices that offer entirely new possibilities (e.g. simultaneous measurements of different physical factors) are in development or already available.

Despite these advantages of the fieldbus it has not succeeded in achieving the long-expected market breakthrough. Although the headlines read "Fieldbus in Process Engineering reaches Adulthood" (3) as early as in 1992. Regular reports on successful applications, e.g. (4), the ranges of products presented at trade fairs (5, 6) and studies on the economic efficiency of using fieldbus technology did not lead to the expected success. What reasons could there be for this delay in market breakthrough, especially in the German process industry? Is it a certain reticence when faced with new, as yet untested technology? It appears not, as laboratory tests and smaller pilot plants confirm that the fieldbus is ready for use. Are there doubts that the fieldbus can provide advantages compared to a Remote I/O system – especially as Remote I/O systems already offer the substantial cost cuts compared to conventional wiring? Are users unaware of the technological edge offered by fieldbus technology, or is it impossible to convey this message? Or are important components still missing for its use?

Users and manufacturers have discussed these questions. The project was launched by Aventis, Infracore and Pepperl+Fuchs. IGR (Interessensgemeinschaft Regelwerke Technik) provides the platform for a specialist discussion between the companies that emerged from Hoechst. During these discussions the idea for the project FuRIOS was born. FuRIOS is an acronym, meaning "Feldbus und Remote I/O – Systemvergleich" (Fieldbus and Remote I/O system comparison) and describes the intention of this study: the two systems should be subjected to a practical system comparison. Not only users have a vested interest in this form of system comparison. Manufacturers of field devices and automation systems are also concerned, as they invested a lot of money over many years in the development of Remote I/O systems and fieldbus components. Today they are still required to equip each device with the option for analogue signalling and with interfaces for both fieldbuses. For how long are manufacturers expected to continue with this parallel development of equipment and systems, which ultimately pushes up the prices? This is the background why the following nine manufacturers provided financial support or, in some cases, technical cooperation in this project: ABB, Emerson, Endress+Hauser, Camille Bauer, Honeywell, Pepperl+Fuchs, Samson, Siemens and Wika.

The following section 2 presents the methodical approach of the FuRIOS project. Section 3 presents the solution developed for fieldbus; section 4 compares the investment costs and section 5 deals with the operative aspects of the fieldbus compared to the Remote I/O. Section 6 provides a summarised assessment of the results of sections 4 and 5. Section 7 then gives an outlook for users and manufacturers. The article concludes with a bibliography and an index of abbreviations.

## 2. Methodical Approach of the FuRIOS Project

Like with the introduction of all new technologies, the introduction of fieldbus technology initially requires a comparison of benefits and costs, whereby the costs must also include the risk that the new technology may lead to plant standstill. Accordingly, which methodical approach could we use to compare new and existing technology? The criteria are:

- Practical approach: a comparison which is intended to assess the suitability for direct use in industrial practice cannot be abstract or theoretical, but must assess the planned production plant in its entirety.
- On time: the comparison must only take into consideration arguments that can take effect in the short-term. Speculation concerning future possibilities confuse the issue and simply make a decision more difficult.
- Completeness: a solution with the new technology must completely satisfy the tasks at hand. Partial solutions that avoid critical points only lead to false statements.
- Definition: hundreds of general conditions must be taken into account in order to determine the costs and benefits. These include standard equipment lists, hour rates, tools and procedures in the respective environments. The comparison must be based on absolutely definite framework conditions if one wishes to avoid being lost in generalities.

In order to meet these criteria, the comparison between Remote I/O and fieldbus was carried out on the basis of a real, newly constructed production plant for pharmaceutical active substances. The comparison solution was drafted on the basis of the following criteria:

- No changes in the plant requirements: any temptation to facilitate or obstruct the comparison solution by making subsequent changes to the requirements was avoided.
- Greatest possible equality of the solutions, e.g. with regard to availability, especially by using partial redundancy.
- Greatest possible equality of the solutions, e.g. with regard to equipped or unequipped reserves.
- Whenever possible, use of the same field devices as in the real plant, provided they are available with fieldbus interfaces. Otherwise devices with similar characteristics were used. Participation of manufacturers in this study had no influence on the selection of equipment.
- "Sensible" solution: the criterion for the solution was that we would build the plant as planned, in accordance with our criteria and standards. Therefore, the comparison solution was not "made feasible" by waiving sensible requirements, but also not "made infeasible" by defining additional requirements.
- No medium-term dependence on one manufacturer: solutions were not accepted if they could only be provided by one manufacturer in the medium-term. The chemical-pharmaceutical industry would not accept any solution of this nature which could therefore not be used as the basis for any technological decision.
- Availability of the PA devices no later than 10/2002.

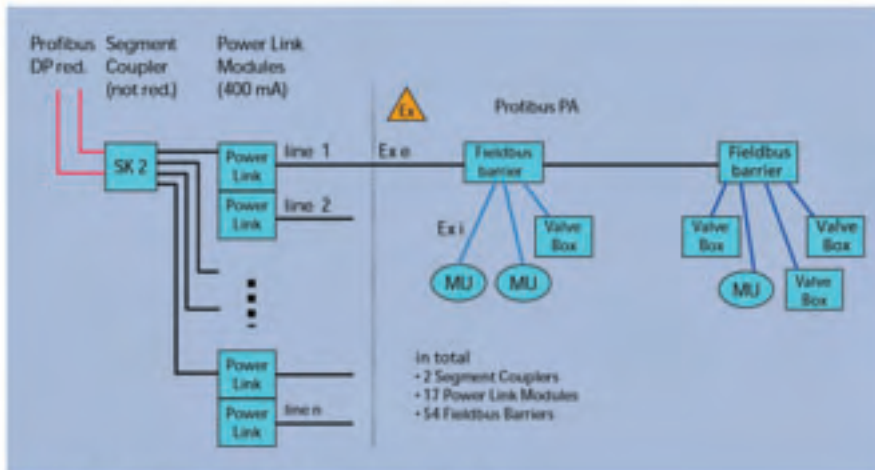

Figure 1: Topology of the fieldbus reference solution

- 62 drives (controlled by means of Profibus DP)
- 2 converters (controlled by means of Profibus DP)

A comparison solution was drafted for this specific plant, based on fieldbus (figure 1). The Profibus PA was selected as fieldbus. The main reason for this is that for this fieldbus currently there are more devices and tools on the market which meet the European requirements for explosion protection.

As base concept of the topology the use of fieldbus barriers and valve interface boxes has been defined. The power to the passive fieldbus barriers is supplied by the bus cable respectively the power link module. This connection is

- Conservative calculation: in general “prudent calculations” were used. It is fair to assume that some of the results will prove to be more in favour of the fieldbus in an a-posteriori analysis than specified in this study.

A comprehensive comparison means that as many other criteria as possible that may become relevant over the life cycle of the plant are taken into account in addition to the investment costs. Systematic reasons dictated a clear separation between the assessment of investment costs (section 4) and operational factors.

In order to ensure the currency of the comparison equipment and connection technologies were required to be available immediately. Of course time is in favour of the fieldbus in this respect, as more and more devices with fieldbus interface are coming to market, while the required periphery such as connection technology, field measurement technology and software are being developed.

### 3. Presentation of the Comparison Solution

Used as a reference was a production plant for chemical synthesis of pharmaceutical active substances, located in building D712 of Aventis in Frankfurt-Höchst, Germany. This plant was constructed during 2001 and 2002 and was commissioned in 2002. It is characterized by:

- Project costs 13.8 Mio. €, including 3.5 Mio. € costs for Process I & C
  - Automated using the process management system Industrial IT by ABB
  - Remote I/O: S900 from ABB
  - Area with explosion risk: zone 1
  - Pharmaceutical requirements (cGMP)
  - Planned using the CAE system Comos PT from Innotec
- The following quantity framework applies:
- 369 Process I&C points connected to Remote I/O (with 821 I/Os)
    - 155 analogue inputs
    - 58 analogue outputs
    - 405 binary inputs
    - 203 binary outputs

designed in the ignition protection class “increased safety” Ex e, while the designated connections of the field devices have the ignition protection class “intrinsically safe” Ex i. Although this deviates from the intrinsically safe design of signal transmission preferred in Germany, we believe it is the most sensible method. The probability that individual field devices must be replaced is considerably greater than changes in the fieldbus segment itself. In that respect the application of explosion protection class “intrinsic safety” Ex i is of greater significance. A rough estimate indicated that if one does away with the fieldbus barriers and designs the fieldbus lines to be entirely intrinsically safe, the fieldbus solution would be considerably more expensive than the solution with Remote I/O. This statement is so important that it should be repeated in other words: the fieldbus would not be economically feasible without the fieldbus barriers!

The use of valve interfaces is also of considerable economic significance. The quantity framework indicates that there are roughly three times as many binary signals as there are analogue signals. Bundling of the binary signals in the valve interfaces significantly reduces the costs. Moreover, some of these field appliances could otherwise not be integrated into the PA bus at all. This, too, would mean that an economic assessment of the fieldbus would be negative. The planned fieldbus solution is characterised by the following figures:

- 2 redundant Profibus DP lines for the field devices,
  - 1 Profibus DP line for drives and converters,
  - 2 segment couplers (SK2), which – unlike the corresponding Remote I/O solution – cannot be made entirely redundant through to the respective PA segments,
  - 17 Profibus PA segments respectively power link modules,
  - 64 fieldbus barriers (bus: EEx e, signals EEx i),
  - max. segment length without spurs 210 m,
  - max. 17 subscribers to one segment (spurs 15 m each),
  - the total cycle time of the Profibus PA slaves is less than 364 ms and therefore meets the existing requirements.
- There was a small number of devices that were not available

with a fieldbus interface (see below). This requires a "rag collector" solution. A brief estimate revealed that Remote I/O solutions would not be economical for these few signals (21 signals). Consequently they were wired directly to the switch room and there connected to conventional I/Os of the process control system. On top of the additional hardware costs for a Remote I/O system it also would create training and commissioning costs, which are omitted here due to the direct connection to the control system.

### 4. Comparison of Investment Costs

This section provides a detailed comparison of the effects of fieldbus installation on the individual components of the process control system. In addition to a description of the technical characteristics it also contains the economic analysis.

#### 4.1 Field devices

The technology that has been used until now has necessitated equipping the control valves with limit switches. The digital positioners report electronically when the limit is reached and transmit this information over the bus. Accordingly, a decision was made to do without the limit switches. In the comparison plant a solenoid valve was positioned upstream from the control valves in order to shut down the flow of products completely. A decision was made in this study to do without this feature when using the fieldbus, as positioners enable a complete system deactivation which can be monitored by the integrated valve position signalling. However, this does not apply to solenoid valves used for safety critical functions. Satisfactory fieldbus components could not be found for the following tasks:

- Signal lamps integrated in control units require so much power that they cannot be supplied by the intrinsically safe fieldbus. Despite the mainly automatic operation, 5 local control units and 2 separate signal lamps were used in our plant.
- For rotation measurements and current conventional quantity measurements the signals come in the form of counting pulses. There are no fieldbus-compatible input devices for these functions, albeit they could conceivably be binary input signals. The actual plant required a solution for four separate rotation measurements.
- While there are fieldbus-compatible analysis devices for the major applications available, such as PH and Redox values as well as conductivity and O<sub>2</sub> analysis, the analysis devices for less frequently used applications such as opacity measurements do not usually come with a fieldbus interface. In our case technical safety requirements dictated the conventional installation of three O<sub>2</sub> measurements.
- In scaling technology, the signals from the scales cells must be processed using an evaluation device. In general, these are not installed in the field, but in the control room and can be controlled and actuated per Profibus DP. As we have already mentioned – and this is also the case

in the existing Remote I/O solution – the 21 specified measurements are wired conventionally to the process management system and connected to its conventional I/O cards. At this point reference should be made to the project methodology of realising a 1 to 1 solution to the greatest possible extent. In specific terms, multi-variable devices were not used (e.g. for flow, temperature and pressure), as these appliances were also not used in the original reference solution and the measurements in the flow and instrumentation diagram would be at different points. Here is additional potential to cut costs if the possibility of using multi-variable devices could be taken into account when drafting the flow and instrumentation diagram.

The economic assessment of the field devices specified in this section indicates an additional cost of 4,489 €. The cost savings for the solenoid valves of 7,400 € are faced with additional costs of 11,889 € for the field devices with fieldbus interfaces. Therefore, the additional costs add up to 0.6 percent, based on the costs for the field devices of 770,000 € for the overall project.

#### 4.2 I/O System

The use of the fieldbus replaces the Remote I/O system with all its components entirely. This refers to 20 Remote I/O systems distributed throughout the plant as well as the corresponding power supply modules and explosion protection barriers. On the other side we have:

- Additional PLC I/O cards (for the "rag collector" signals)
- Components of the fieldbus system (fieldbus barriers, valve interface boxes, segment couplers, power link modules)
- An additional process-near component was also required for the process control system in use, as the components offered by that specific DCS manufacturer offered only four Profibus DP connections, but five were needed. The corresponding additional costs are specifically linked to this DCS manufacturer, as other systems have more and sometimes less than four fieldbus connections per process-near component. If we had done a more plant-specific allocation of the functions to several process-near components this additional cost would not have occurred. Therefore the PA solution would have been even more cheaper.

The economic assessment of the I/O systems described in this section leads to cost savings of 76,212 €. The cost savings of 138,562 € for the unnecessary Remote I/O system are faced with additional costs of 46,350 € for all fieldbus components as well as 16,000 € for an additional process-near component. The cost savings amount to 18.1 percent, based on the costs for the I/O system of 420,000 €.

#### 4.3 Engineering of the Field Technology

The Remote I/O systems that have been used until now require a significant level of engineering costs; in addition, the considerable space they required necessitated specific

consideration in the location planning. The decentral I/O cabinets had to be positioned throughout the plant and equipped with I/O cards in an optimal way. Therefore one has to define in advance which devices will be connected to which cabinet. Very often this is an iterative procedure. Detailed plans with corresponding documentation were necessary for the Remote I/O. Some I/O systems require a special calculation of the heat dissipation in order to comply with the requirements of explosion protection. The intrinsic safety has to be confirmed for each specific combination of field device and Remote I/O card.

When using fieldbus technology many of these activities are not necessary while others are considerably simplified. The topology of the fieldbus is rather simple with just a few, compact components inside the plant, therefore requiring considerably less planning. Due to the free combination of devices connected to a fieldbus segment a more precise allocation in the plant can be achieved compared to Remote I/O, without any additional expense. Thanks to FISCO the confirmation of intrinsic safety is considerably easier.

The used planning tool has a significant influence on the costs relating to the plant documentation. If a databased CAE tool is used, like Aventis uses the Innotec tool "Comos PT", the documentation costs are low – for both the Remote I/O and the fieldbus. However, the cost savings that can be achieved with fieldbus are firstly due to the fewer connections, such as with the valve positioner, and secondly due to the fact that the PA connection is identical at all devices. This means that the otherwise necessary transfer of device and manufacturer-specific graphic symbols and connections to the standard library of the CAE tool is no longer necessary.

The economic assessment of the fieldbus technology engineering described in this section indicates to cost savings of 9,076 €. The main items are the obsolete I/O allocation planning, the simplified confirmation of intrinsic safety and the simplified creation of typicals in the CAE system. These savings reflect 3.2 % of the total costs of engineering in the project, amounting to 280,000 €. The cost savings would have been considerably greater if the plans had not been created with the CAE system, but rather – like Aventis did until two years ago – with a relatively high cost for manual labour. Estimates indicated that the fieldbus cost savings would then have been 33,188 € or 11.9 % of the engineering costs.

#### 4.4 Engineering of the DCS

At first glance it may appear surprising that the choice between Remote I/O and fieldbus influences the DCS engineering. Nonetheless, this influence is really quite significant for the overall result. This is ultimately due to the fact that the level of fieldbus standardisation is rather high – unlike with Remote I/O. When using Remote I/O separate programming respectively evaluation is necessary for each

device to define the significance of each code pattern of the status bytes. Fieldbus status information is coded in a standardised manner so that device-specific configuration, implementation and analysis of typicals are not necessary. This allows configuration in the DCS independent of the measuring devices and to a certain extent independent of the measured factors, too.

Another difference becomes obvious when planning the DCS: Remote I/O connects the field devices via an interface as "external systems", whereas with fieldbus the communication with the devices is transparent, as if they were connected directly to the DCS. This facilitates engineering, commissioning and testing.

The economic evaluation of the DCS engineering described in this section indicates cost savings of 24,795 €. This amounts to 4.7 %, based on the total costs of engineering; it accounts for almost twice as much, based on DCS engineering alone.

#### 4.5 Installation

By changing from conventional wiring to Remote I/O the greatest potential for savings on installation costs has already been realized. Former conventional plant communications had required local distributors, multicore cables and patch cabinets. Later Remote I/O systems were installed directly in the field, the only individual connections were between field device and Remote I/O. From the latter to the control room a bus cable was used. All that was required in addition to the bus cable was an auxiliary power supply to the Remote I/O station. Considerable cost savings have been achieved in wiring, in the cable tracks and in terms of space in the control room. But this was not a topic of this study.

Now costs can be even more reduced by changing from Remote I/O to fieldbus. In general, the cable lengths for the spurs are shorter, since the fieldbus barriers are more decentralized located than the Remote I/O stations due to their greater number. The installation of the extremely small and light fieldbus barriers forms no problem, whereas the large Remote I/O stations must be assembled very carefully. Wiring of the I/O stations with auxiliary power supply is also no longer necessary. Due to the larger number of fieldbus segments and the "rag collector" signals the number of cables to be laid between the field and the control room remains approximately the same. The economic assessment of the installation described in this section leads to savings of 10,732 €. These are 1.5 percent, based on the costs of Process I&C of 700,000 €. Although this is not very much, it must be seen in the context with the high savings that were achieved already by replacing conventional wiring with Remote I/O.

#### 4.6 Calibration and Qualification

In general, the type of connection technology has no influence on the calibration of the equipment and the costs this accrues. However, the situation is very different with regard to the calibration and qualification the process control

sification of the measurement values and therefore does not have to be calibrated, the conventional analogue signal path is subject to faults, thus generating calibration, qualification and documentation costs. Furthermore the setting and validation of the measurement range is no longer necessary; only a plausibility test is required for the qualification.

The economic assessment of the calibration and qualification described in this section leads to savings of 5,967 €. This amounts to savings of 4.3%, based on the total costs of calibration and qualification of 140,000 € for the whole project.

## 4.7 Commissioning

As already mentioned on several occasions, the integration of the field devices into the overall process control system works considerably better with the fieldbus than with the Remote I/O. The reduction of error sources, the use of standards and the easier fault diagnosis due to the greater transparency mean that commissioning is much faster. Testing of the entire, readily installed Process I&C point, the so-called loop check, is no longer necessary. It has only to be checked whether the correct device is connected and whether it emits a "sign of life". The economic assessment of the savings relating to the commissioning described in this section amounts to 2,400 €, based on half an hour savings per analogue device. This amounts to 2.3 %, based on a total cost of commissioning of 105,000 €.

## 4.8 Summary of the results

Table 1 provides a summary of the additional costs respectively savings specified in the above chapters. In total, the savings in terms of Process I&C investment costs amount to approx. 125,000 €, or 3.6 % of the total Process I&C costs. The table also indicates that some parts of the project are not affected by the communication technology, for example the electrical engineering, the analysis appliances and the project realization itself. If one deducts these areas, the total savings amount to 4.2 % of the relevant Process I&C costs. Reference should be made once more to the influence of the used CAE tool on the savings in engineering, as indicated above in section 4c. Without this influence, the savings would amount to 4.2 percent of the total Process I&C costs or 5.0 percent of the relevant Process I&C costs.

## 5. Comparison of Operational Factors

The previous chapters dealt with the effects of the fieldbus on the investment costs. We were dealing with "hard facts" that could be calculated precisely. The following sec-

**Table 1: Influence on investment costs (all prices in €).**

	Costs RIO	Price changes	Costs PA:	Min. (%)
Electrical.: 0%	140,000	0	140,000	0,0 %
Analysis devices.: 0%	140,000	0	140,000	0,0 %
Project handling: 0%	280,000	0	280,000	0,0 %
Field devices: +0,6%	770,000	4,489	774,489	0,6 %
I/O-System: -18,1 %	420,000	-76212	343,788	-18,1 %
DCS incl. Engineering.: - 4,7 %	525,000	- 24,795	500,205	- 4,7 %
Installation: -1,5 %	700,000	-10,732	689,268	-1,5 %
Calibr./Quality: - 4,3 %	140,000	- 5,976	134,024	- 4,3 %
IBS: - 2,3 %	105,000	- 2,400	102,600	- 2,3 %
Engin.: - 3,2 %	280,000	- 9,076	270,924	- 3,2 %
Total all Process I&C	3,500,000	-124702	3,375,298	-3,6 %
Total relevant Process I&C	2,940,000	- 124,702	2,815,298	- 4,2 %

tion describes the other effects and evaluates them to the greatest possible extent. Firstly, this relates to the effects on the life cycle of the plant which cannot be defined as precisely as the investment costs. Secondly, it also relates to the indirect effects, which are manifest, for example, in higher production rates of the plant and therefore in benefits outside of the Process I&C area. Because these factors are always dependent on the type of production and market situations, the actual benefits cannot be estimated in a general sense. Readers are encouraged to determine the effects in their industries and production plants themselves.

### 5.1 Influence on the project running time

Section 4.7 has already made reference to the considerable effects on commissioning. Whereas that section dealt with the direct savings in investment costs over the course of the project, this section discusses the influence on the project running time.

Our calculations revealed that – if there are realistic team sizes – four days could be saved during installation, five days during qualification and two days in commissioning. This may not appear sensational at first glance if one considers the 12-18 months that are usually estimated for such a project. However, upon detailed analysis of the project plans one can see that the installation, the qualification and the commissioning of the Process I&C are always time critical areas. Put in colloquial terms: the Process I&C people are always the last in and have to be the first out. So it is fair to say that the use of fieldbus can speed up the overall project by about 10 days!

Any attempt to estimate these savings in Euros and Cents is doomed to failure. The benefit depends on whether these two weeks can be turned into earlier market presence, a bigger market share or an increase in turnover or whether they are wasted somewhere else in the project, in production or in marketing. In general, however, the pressure to meet tight project deadlines is growing from year to year, so any acceleration in project finalization is of considerable value. In order to estimate this value, readers are rec-

ommended to calculate the turnover of a new product in two weeks, based on the annual turnover, and the corresponding profit margin in their respective markets – the project acceleration could create considerably more value than the entire savings in investments!

## 5.2 Influence on the training of technical staff

In general, Remote I/O as well as fieldbus requires trained, well-qualified process control specialists. We estimate that technicians require two days of training on fieldbus technology in order to learn installation, diagnosis and fault repair. The same amount of time would be needed for training on Remote I/O. However, the manufacturer specific Remote I/O variants require specific training for deciphering the codes. Due to the standardized protocol this is not necessary with fieldbus. These savings are estimated to be 2.5 days of training per technician. In case of three technicians within the plant we estimate the savings on training to be about 4,000 €.

This is a remarkable result since it contradicts the general assumption that a new technology is always more complex than the old, replaced technology and therefore training levels are continually rising. This result is due to the standardisation of fieldbus which avoids special training as well as to the increase of transparency and constancy thanks to fieldbus technology. The system now works fully digital, thus gaining the advantages of this homogeneity.

## 5.3 Influence on quality

Due to fieldbus two signal conversions are omitted: often the measurement signal is generated digitally and then converted to an analogue output signal, which then is re-converted to digital in the process control system – and vice versa for actuators. Two systematic sources of errors are removed with the disappearance of these signal conversions. Fault reproduction no longer needs to be considered and the entire signal loop is exactly as accurate as the sensor or actuator itself. Ultimately the measurement tolerances are significantly smaller. This could either be used for more precise measurements or settings with the same field devices or to achieve the same total tolerance with devices of lower tolerance quality. Especially the latter could become economically significant in cases where up to now the required tolerances could only be reached by special and therefore expensive precision measuring equipment. A general statement on the economic benefit cannot be given here – but it could be very significant.

Two more factors influence the total quality of the process control system: Many chances for errors are avoided directly at the source, e.g. if the alias values have not to be attributed individually any more. Errors which cannot occur at all cannot lead to losses in quality.

Furthermore – and this is second factor – error detection and correction is much faster due to the transparency of fieldbus. Therefore the resulting damage is considerably less. An economical assessment of these factors is not possible at the moment, too.

## 5.4 Influence on fault correction

The fieldbus increases the transparency of the system. Therefore fault detection is much faster or, even better, faults are reported actively. Fieldbus technology allows the use of “intelligent” devices featuring superb self-diagnosis, even up to signalling the need for preventive maintenance. On top of the faster fault detection the increased reliability of error diagnosis will have a positive influence, too. If the devices run a reliable self-diagnosis and send an “ok”-signal they need not to be removed, tested and re-installed on suspicion.

The calculated direct economic benefit of this simplified error handling is disappointingly low. We estimate about 500 € a year. This is due to the low failure rate of the nowadays technology – we estimate it at 0.5 % per year. This again is a direct success of the rather conservative habit of commissioning new devices only after extensive testing in the laboratories of NAMUR member companies or after solid operation experience.

The indirect benefit is several times bigger but cannot be calculated universally. However, if fieldbus technology helps to avoid faulty batches or the loss of just one day of production, this benefit may amount to several 100,000 €.

## 5.5 Influence on maintenance and inspection

Section 5.3 describes how possible error sources in signal conversion and transmission are avoided due to fieldbus. Therefore the calibration of the production line during the annual testing is not necessary any more. This annual testing is mandatory, at least in pharmaceutical production environments. In the reference plant this applies to 25 calibrations, adding up to savings of 2,500 € p.a. Furthermore it allows to omit the calibration of an installed device by simply replacing it by a readily calibrated one. This speeds up the annual tests and shortens the period of production interruption, which has a significant economic value.

Another topic cannot be clarified definitively. It is possible that the calibration cycles of the sensors can be increased significantly – even beyond the current minimum of once per year.

This results from the fact that very often the sensors have a higher long-term stability than the signal conversion electronics in the analogous devices. Since the signal conversion is omitted the calibration cycle could be adjusted to the long-term stability of the sensor. Once this will be accepted by the quality departments and control boards – surely only after extensive practical experience – even more savings are possible. In terms of the Process I&C of the reference plant this would mean 7,500 €, the operational benefit due to reduced downtimes cannot be estimated.

## 6. Assessment of the Results

### 6.1 Assessment of the investment costs

The above presented savings in the Process I&C costs which amount to 3.6 through 5 percent, depending on the perception, may seem disappointing at first glance. The values of about 20 percent which former studies indicated led people to expect more. However, it is to be recalled that these studies (8) determined the potential savings relating to fieldbus technology in comparison with conventional wiring. Roughly it can be said that Remote I/O saves about 15 % over conventional wiring and fieldbus technology saves an additional 5 %.

Taken realistically, greater savings in investment costs could not really be expected by changes of the communication technology alone, as the number of cables laid between the control room and the field remains approximately the same. However, these savings are relevant: it is a considerable leap if the introduction of a new technology leads to a 5 percent drop in investment costs for a certain field – even without the discovered additional benefits during the life cycle. Which other technology leap over the last few years has generated savings of 5 % off overall costs in other fields such as construction engineering or apparatus engineering?

### 6.2 Assessment of the operational factors

Besides some relatively small factors, like training or costs of Process I&C maintenance, there are major changes in the operational factors: if plants can be put into operation faster thanks to fieldbus technology, if they have less downtime during malfunctions or can be run with greater precision, then this is the major benefit of fieldbus technology. One day of production profits in a plant operating at maximum capacity can easily generate 500,000 €. Or vice versa, one day of downtime can destroy the same amount. Unfortunately the benefit potentials cannot be determined universally since the influences of plant load levels, market situations and profit margins are far too big. However, the benefits in operation surpass the savings in investment costs by far. From our perspective it is a pleasant bonus that these benefits in operation – unlike as with most other innovations – must not be paid for by higher investment costs, but are accompanied by additional savings, even if they are relatively small.

### 6.3 Assessment of the methodology

An assessment of results would be incomplete without an assessment of the methodology. The methodology described and substantiated above led to a conclusive, comprehensible assessment within a relatively short period of time. Of course it cannot yet be concluded with an evaluation of a real project, since the decision for future plant designs with fieldbus will be based on this study. It has to be noted explicitly that there is a certain risk to find some differing results in a real practical comparison.

In a methodical sense the approach of drafting a comparison on the basis of a real, operational plant is highly in danger of subjective errors. The selection of plant location, size, type and equipment leads to specifications that cannot be generalized. Furthermore, the point in time of this study could have a significant influence, too. The results may be different in six months from now. Accordingly, one should be careful in transferring the results to other plants or in assuming that the results are generally valid. There may indeed be plant sizes for which the Remote I/O solution is the best. The evaluation of continuous processes with respective availability requirements may lead to different assessments. With revamps of existing plants Remote I/O allows to continue using the installed field devices. On the other hand, for example, fieldbus technology would be even more beneficial to larger, more spread out plants than our reference plant. Specialists around the world should feel invited to apply the methods of this study to other plant types and to communicate the results so that more general statements will be possible.

Another uncertain area of the FuRIOS project is that the comparison was carried out on the basis of Profibus PA and not Foundation Fieldbus. Without having considered the details of a solution with FF, we would venture the opinion that the results of a study with Foundation Fieldbus technology would be similar. Advantages and disadvantages of the different fieldbuses would be apparent here and there, but this would not affect the result by anything more significant than 10 %.

One more critical statement about the FuRIOS project is necessary: This study was carried out to the best knowledge of the authors, using their experience with fieldbus test systems. However, there is a lack of practical experience. Some assumptions may be overly cautious; problems may occur in the implementation of a real project which have been overlooked here. Most certainly there are "teething problems" to be expected in the first projects, which could eat away the estimated savings. Faster commissioning is also unlikely to be possible in the first project.

## 7. Outlook

The methodology of this project was the 1 to 1 reflection of a real plant realized with Remote I/O to a plant using fieldbus. Used cleverly, the fieldbus technology will lead to further cost savings and increased benefits. On one hand the user is asked to be flexible in his thinking while on the other hand the manufacturers face new requirements.

### 7.1 Outlook for users

The fieldbus technology is the technological platform for further development of the field devices. Already the first products are available: So-called multi-variable devices can measure several physical factors at the same time, for example flow rate, pressure and temperature. Devices of this kind are inexpensive and – thanks to fieldbus – can be connected just as easily as single value devices. In FuRIOS

it was not possible to use them anywhere since temperature and pressure measurements were never taken at the same pipe or at the same installation point. The users are requested to become aware of the possibilities of multi-variable devices and to take them into account when drafting the flow and instrumentation diagram.

Fieldbus is the technological basis for new device developments. A rod probe that measures a temperature profile, a valve that counts how often the valve opens, an analysis device monitoring itself – only fieldbus allows a sensible and efficient integration of all this into process automation. This insight was published years ago: "Fieldbus technology as the driving force behind automation engineering" was the name of an article back in 1999 (9). The common term at the moment is enabling technology, which means the same thing. Fieldbus represents an innovative technological platform – manufacturers and users have to decide which devices will use this platform and how they will be utilized. Fieldbus is also the fitting technological basis for asset management systems. Until now, these systems have required separate bus systems for transmitting the device information. This is no longer necessary since fieldbus transports these informations. This may (finally) help asset management systems to achieve the breakthrough that has not happened until now. However, the discussion on how the tasks should be optimally distributed between CAE system, asset management system and ERP system is not over yet. The cost/benefit analysis of asset management systems has been consciously left out of this study, it has to be discussed at some later date.

## 7.2 Outlook for manufacturers

Not only users are encouraged to make more intelligent use of fieldbus than simply replicating current tasks 1 to 1. Manufacturers are also called on for further developments, in particular to pursue the following ideas:

- Feeder devices (power modules) with a higher supply current (considerably more than 400 mA) would be sensible, as many appliances – sometimes with good reason – require considerably more than 10 mA. A higher supply current would not only reduce the number of fieldbus lines, it would also enable more and more devices to change from four-wire supply to two-wire supply.
  - A valve interface box for Profibus PA with bus connection in increased safety Ex e would allow the control of more powerful intrinsically safe solenoid valves (this is already available for Foundation Fieldbus).
  - A "mini Remote I/O" for the Profibus PA, also with bus connection in increased safety Ex e, would make conventional wiring (for frequency inputs, too) or a separate Remote I/O as "rag collector" superfluous (at the moment, the only available solutions use auxiliary power).
  - The address scope of 126 addresses with Profibus DP is a limiting factor. The standardisation committees should attempt to achieve a revision of this limit.
- A process-near component should not be limited to two redundant Profibus DP lines only. This increases the number of components unnecessarily. However, many systems already satisfy this wish.
  - Software tools for calculating the manufacturer specific connections are required. At the moment, not all manufacturers of fieldbus components offer them.
  - A simple bus monitor system for Profibus PA for diagnosis at the Ex segment would be sensible. The FF already offers it.
  - At the moment, Profibus PA does not have the option of continuous redundancy, at least up to the respective PA segment.

*Manfred Dietz, Infraser/Hoechst, Harald Hauch and Josef Will, Aventis, cooperated on the project in addition to the named authors. Staff from the manufacturers involved also cooperated, and our thanks goes out to them at this point.*

### Bibliography:

- (1) Gangbarer Weg – Remote I/O-Systeme in der Prozessautomation. *Chemie Technik*, 28 (1999), Nr. 4, S. 38–40.
- (2) Klemm, E.: Internationale Feldbusnorm IEC61158 ist Realität. *et*, Heft 6/2000
- (3) Hils, F., Lindner, K.-P.: PROFIBUS – Der Feldbus für die Verfahrenstechnik wird erwachsen. *atp – Automatisierungstechnische Praxis* 34 (1992), H. 12, S. 661–667.
- (4) N.N.: Zielsichere Vorlage. *Chemie Produktion*, H. 3/1998, S. 44–47.
- (5) Rathje, J.: Der Feldbus in der Verfahrenstechnik. *atp – Automatisierungstechnische Praxis* 35 (1993), H. 2, S. 135–137.
- (6) Rathje, J.: AICHEM 97: Der Feldbus kommt ins Rollen – Ein Situationsbericht. *atp – Automatisierungstechnische Praxis* 39 (1997), H. 10, S. 56–59
- (7) Max, G., Heidel, R., Frehse, K. P.: Wirtschaftlichkeit des Feldbuseinsatzes. *atp – Automatisierungstechnische Praxis* 34 (1992), H. 9, S. 507–512.
- (8) Rathje, J.: Braucht die chemische Industrie den Feldbus? *atp – Automatisierungstechnische Praxis* 36 (1994), H. 4, S. 22–30.
- (9) Neumann, P.: Die Feldbustechnik als Motor der Automatisierungstechnik. *atp – Automatisierungstechnische Praxis* 41 (1999), H. 7, S. 27–34

# Operate and Observe

---

## Abbreviations:

CAE:	Computer Aided Engineering
DCS:	Distributed Control System
FuRIOS:	Fieldbus and Remote I/O system comparison
Process I&C:	Process Instrumentation and Control
FISCO:	Fieldbus Intrinsically Safe Concept
PLC:	Programable Logic Controller
Profibus DP:	Decentral Periphery (see IEC 61158)
Profibus PA:	Process Automation (see IEC 61158)



Dr.-Ing. Thomas Tauchnitz is head of the Technology and Projects group within the Technical Engineering Active Substances Department at Aventis Pharma Deutschland GmbH. Within NAMUR, he is coordinator for working field 2 Integrated Solutions and Systems. He heads the working field Management Technology within IGR (Interessengemeinschaft Regelwerke Technik).

Address: Aventis Pharma Deutschland GmbH, ITW, D610, D-65926 Frankfurt/Main, phone (069) 3 05-41 94, fax -8 30 98, e-mail: Thomas.Tauchnitz@aventis.com



Dipl.-Ing. Wilfried Schmieder is head of the Project Process Control Technology team within the Technical Engineering Active Substances Department at Aventis Pharma Deutschland GmbH. Address: Aventis Pharma Deutschland GmbH, ITW, DS581, D-65926 Frankfurt/Main, phone (069) 3 05-1 21 22, fax -31 10 46, e-mail: Wilfried.Schmieder@aventis.com



Dipl.-Ing. Sven Seintsch is head of analyses on various fieldbus test installations within the test laboratory of Infraserf GmbH & Co Höchst KG. He is member of the NAMUR working group 2.6 Fieldbus. He is also head of the working group Fieldbus within IGR (Interessengemeinschaft Regelwerke Technik).

Address: Infraserf GmbH & Co Höchst KG, MSR-Technik, Prüflabor, D710, D-65926 Frankfurt/Main, phone (069) 3 05-1 32 60, fax: -1 59 78, e-mail: Sven.Seintsch@Infraserf.com

## Push-button telephones were the first step on the way to the mobile phone

New technological platforms in the field of automation technology can only be achieved with the fieldbus

*The results of the fieldbus and Remote I/O system comparison FuRIOS caused quite a stir at the NAMUR general assembly beginning of November 2002 and triggered off renewed discussions between manufacturers and users about the application of the fieldbus technology. Over the last few months several enterprises have decided to start with fieldbus projects. FuRIOS could prove to be the breeze that fans the further development of the fieldbus.*

*The journalist Dr. Christine Eckert spoke about this with two of the initiators of the FuRIOS study: Manfred Dietz from Infrasero Höchst and Dr. Thomas Tauchnitz from Aventis Pharma Germany.*

**Dr. Eckert:** FuRIOS compares the costs of a real, working plant equipped with Remote I/O systems with those of a calculated one-to-one reference solution based on the fieldbus technology. How does that work?

**Dr. Tauchnitz:** Well, it's basically a thought experiment. We take a reference plant – one that is so new that it would be equipped in exactly the same way again – and we ask the question: How would it have looked like if it had been based on the fieldbus? It's a very simple concept. Discussing the benefits and disadvantages of fieldbus on the basis of virtual solutions is too complex and abstract. Other companies have other methods, they structure their plants differently. We tailored our approach to our plants. The other users should now look at the calculations for their plants. I think the comparison of the results could be very interesting.

**M. Dietz:** *There would always have been doubts as to whether our assumptions were realistic. Now the users can say: "Our plants are different" if they want, but they cannot go past the fact that a real plant has been investigated.*

**Dr. Eckert:** What were the criteria for choosing the components for the calculation?

**M. Dietz:** *We had an unrestricted choice of the fieldbus components. It must be said, however, that the Pepperl+Fuchs FieldBarrier is currently the only fieldbus barrier we accept, as it is the only one with the required galvanical isolation. In the case of the couplers, the control system was the decisive factor. The same control system will be installed in the new plant as is in the reference plant. Of course, with a one-to-*

*one solution, nothing can be changed here. The use of the ABB control system inevitably leads to the use of Pepperl+Fuchs couplers. They are not in the program merely because Pepperl+Fuchs were the instigators of FuRIOS. It would quite simply have cost us our credibility if we had chosen couplers from someone else.*

**Dr. Eckert:** Why are the segment couplers, valve coupler boxes and fieldbus barriers so crucial for the economic feasibility?

**Dr. Tauchnitz:** They make it possible to connect a larger number of devices to a PROFIBUS PA line. This saves on installation and cabling costs. If we assume that 500 signals have to be collected and each PA line can deal with only six or seven signals, 80 segment couplers would have to be used and 80 cables have to be led? from the non-ex area to the hazardous area. This costs twice as much as 40 segment couplers and 40 cables. If we had had such a small number of signals per PA line and needed that many cables for it, it would quite simply have been more expensive than the Remote I/O.

**M. Dietz:** *In other words, connecting seven devices to one line means only one seventh of the cables are needed. Just imagine the fieldbus as a kind of high-tech washing line – you hang your shirts and trousers on it and save yourself a lot of work compared to if you had to drive new posts into the ground and stretch out new washing lines for each garment individually. It halves the expenditure for installation and components. A doubling to up to 30 devices is possible once the energy supply problem is solved. With 2 amperes of supply current we could have hung a lot more washing out to dry – to stay with that metaphor. At that time we didn't have a 2 ampere coupler available.*



However, we currently have one under test. FuRIOS has shown that fieldbus barriers with more supply current are needed. If we had started the project a year earlier, the result would have been clearly in favour of the Remote I/O systems. I am absolutely convinced of that. As it turned out, this was just the right point in time, although we didn't know that beforehand. With every year that passes, the result will be more and more in favour of the fieldbus.

**Dr. Eckert:** What speaks for the fieldbus technology and what additional possibilities does the new technology open up?

**Dr. Tauchnitz:** With regard to the required investment, the result is quite sobering. Saving four percent on the investment costs is not chicken feed, but it's not the world either. A cost calculation without couplers, fieldbus barriers and valve coupler boxes would presumably have been four percent more expensive. Then we would have had to base our argumentation on the life-cycle costs alone. The way it turns out now, it is much simpler. Both the investment costs and the life-cycle costs can be named as benefits. In the internal discussions those four percent are definitely an issue.

**M. Dietz:** FuRIOS compares fieldbus and Remote I/O with the same equipment functionality. Today I always end up with the same measurement, regardless of whether the pressure transmitter is connected to the fieldbus or to the Remote I/O. In five years from now the discussions will be completely different. The additional opportunities provided by the fieldbus technology couldn't even be considered in this comparison of the two systems. At this moment the difference is minimal, but that will change. Those who have fieldbus will be prepared for a world of innovative measurement technology. Those with Remote I/O systems will only be able to look back to the past. There is nothing new coming to keep Remote I/O up to date.

**Dr. Tauchnitz:** Mr. Rathje from Bayer, a member of NAMUR, once said: "When we have fieldbus, we will save 40% of our costs". I like to use the analogy of a mountain. Remote I/O takes us around 90 percent up the mountain. That means around 36 percent of savings. Many people now say: It isn't worth changing the technology just to

get that little bit closer to the summit – the last four percent. But what they are forgetting is that the mountain is a volcano. It is growing all the time. New technologies are becoming available that don't work without the fieldbus. For example the famous thermometer probe. It measures the temperature at ten places in the boiler. That simply isn't possible with 4 to 20 mA. You can only make full use of the growth of this mountain and the benefits of the technology if you climb that last little bit as well. Technologically speaking the Remote I/O was not an innovation. What remained was the same mountain and an analogue signal.

**Dr. Eckert:** What benefits do modern field devices have and what might the device of the future be like?

**M. Dietz:** A field device connected to Remote I/O is an appendage tagged onto the system, and you have to see how you can gain access to the parameters. A field device on a fieldbus is an integral part of the system. That alone just about says it all. With Remote I/O systems you isolate yourself from this development. The field device of the future will be multi-functional and will make asset data accessible. Even if we only want to mention diagnosis briefly – we can expect all sorts of things to happen there. All the companies that currently speak of diagnosis on the field devices have just developed the kilometre counter. If I take my car to the garage nowadays, they stick a diagnosis plug into it and it tells me what I did wrong, what is broken and what maintenance means. The basis for all this was the kilometre counter, and in the field of diagnosis tools we have only just reached this level. What can be expected from future diagnosis alone already justifies the fieldbus. Diagnosis means: I ask the appliance if it will require servicing already at the next plant standstill in four weeks or whether it can wait till the following standstill in thirteen months time. This is the way towards predictive maintenance and can only be realized with the fieldbus technology.

**Dr. Tauchnitz:** Only the fieldbus technology can keep up with the growth of the mentioned volcano. The devices that will be on the market in ten years time will have possibilities that cannot be utilized with 4 to 20 mA. Dr. Kegel from Pepperl+Fuchs once compared this to the devel-



opment of the telephone: "At some stage the dial had to be replaced by buttons. It didn't have any significant benefits at the beginning, but mobile telephones would never have been possible without push-buttons. Today we can do our banking with the cellular phone or send pictures all over the world at the touch of a key. So the step from the dial to the button was essential. And this is exactly the same step we have to take today, otherwise we won't be able to make the technological transition to a new platform.

**Dr. Eckert:** The industry park Höchst is a pioneer in this field. What problems do you anticipate when building the first plant?

**Dr. Tauchnitz:** With Remote I/O systems we already have the PROFIBUS DP interface in operation. Instead of Remote I/O a fieldbus isolator will now be used and the fieldbus barriers and valve coupler boxes lie beneath them. If there ever will be a communication disturbance between the process control system and one of the field devices, that device and only that one will have a problem. I don't see any risk that our complete plant could be brought to a standstill. It is still the same PROFIBUS DP as is being used with the Remote I/Os, and it has proven itself there.

**M. Dietz:** The team at Infraserp Höchst will test the communication of the entire system in advance and will support the project team throughout the entire completion time. The key to success is the timely training of planners, plant administrators and management staff. It would be very counter-productive if the staff suddenly had to go to a training course just when the commissioning of the plant is entering the critical phase. I hope that we will be able to start the training courses for the PROFIBUS PA at the beginning of March latest.

**Dr. Eckert:** Won't the other users wait until all the start-up difficulties have been done away with?

**Dr. Tauchnitz:** There are no signs that the other companies intend to sit back comfortably and watch for a year and a half until our plant is finished. In those eighteen months they would acquire new equipment that is based on a tech-

nology that won't support new appliances in five years time. Engineers don't like to gather old material that costs, and then has to be disposed of. Using a new technology holds the same risk than sticking too long to an old one. We are convinced that the project will be a success, otherwise we wouldn't be doing it.

**M. Dietz:** All plants are unique. As long as there is new equipment being launched onto the market there will be start-up difficulties. This is true of all devices, be they fieldbus or not. We calculated everything in FuRIOS. Even more, the testing laboratory at Infraserp Höchst is at our disposal at all times, with its manpower and specialist know-how. If any suspicion should ever arise that something doesn't work properly, every manufacturer involved will do everything in his power to solve the problem. Do you think a project fails because one manufacturer doesn't do what is required of him? Perhaps the follow-up projects will be a little less expensive, but never before has a technology been as perfect before its market launch as the fieldbus is now. We are convinced that it will work. If we weren't, how could we possibly expect others to be?



## From theory to practical operation

Aventis builds pharmaceutical production plant based on FuRIOS Study



*Two years ago Aventis Pharma Deutschland and Infracserv Höchst Technik conducted the FuRIOS study (Fieldbus and Remote I/O System Comparison) in order to evaluate the cost/benefit aspects of fieldbus technology and to increase its acceptance in the process industry. This system comparison convinced the producer of pharmaceuticals and soon after publication of the study Aventis started to turn these theoretical considerations into real practice. The Ketek plant is the first automated production plant which follows the recommendations of FuRIOS.*



FieldConnex® from Pepperl+Fuchs in the Ketek tank farm:

The new plant for pharmaceutical agents produces several stages of the new antibiotic Ketek for treatment of acute respiratory infections. The instrumentation of the plant is based completely on fieldbus technology, which makes it one of the most modern of its kind. The only exceptions are the safety oriented applications and a few remaining conventional signals. The cost for the Process C&I are about 12 million Euro. The plant is divided in 200 Profibus PA segments with a total of 1.600 Profibus PA field devices. Two production lines comprise 15 device types of seven different manufacturers, all of them working fully interoperable. The control system is supplied by ABB. The complete fieldbus installation for device connections in explosion hazardous areas follows the fieldbus barrier concept and is realized by means of the FieldConnex system of Pepperl+Fuchs.

„Ketek is one of the largest projects of our project team. In some areas of engineering and construction we have been supported by Siemens“, says

Bodo Bartscheit, project manager Process C&I at Aventis. Not without some pride, since the complete project was under the full responsibility of the team. In order to optimize the coordination with the engineering company his colleague Harald Hauch, project manager automation, acted as interface between plant operator and service companies. For the creation of commissioning and installation procedures as well as training of personnel Aventis took the specialists of Infracserv Höchst Technik on board, thus taking advantage of the experienced team which had already been involved in conducting the FuRIOS study.

FuRIOS is a classical evaluation which took a real plant, working on Remote I/O technology, and projected it 1:1 to fieldbus technology – with absolutely identical requirements. With the Ketek project Aventis followed these prerequisites and designed topology and instrumentation accordingly. “Maybe we designed 1:1.01 on fieldbus. But in general the design work went as usual“,



says Dr. Thomas Tauchnitz, former manager of technology and projects at Aventis agents. Many of the advantages of digital technology can only take effect if the planner uses the new possibilities in an intelligent way. But here the practical experience is missing. „The engineering teams still follow the conventional technology since they know all its nooks and crannies. One uses his leeways only after a certain experience is gained“, knows Manfred Dietz, head of the test laboratory at Infracerv Höchst Technik. This counts especially regarding the application of multivariable devices which had not been considered in FuRIOS. „At 10 out of 2,000 measuring points we used the functionalities of multivariable devices. Here we go one step further than FuRIOS“, explains Bartscheit.

### New technology means rethinking

All team members underestimated the demand on training. One point which is unfavourable for fieldbus only at the first glance since the demand is much higher with Remote I/O technology. With Remote I/O Systems new field devices and new operation philosophies show up all the time and the personnel has to be trained anew for each project. „Somebody fit on Profibus is fit. It is one single learning process only“, confirms Dietz. „With each technology change the initial trainings take the most effort since one has to start at zero.“ The manager of the test laboratory knows what he is talking about since he and his team conducted all Profibus training sessions during this project.

Everybody has to learn the new technology – installation personnel, planner, engineers and managers. „In order to take full advantage of the fieldbus benefits everybody has to know what this technology can do and what not“, says Dietz, and Tauchnitz adds: „Every trainee learns how to connect 4 mA ... 20 mA in his first year. How to connect Profibus PA? This we had to work out, write down and teach to every employee.“ The specialists are sure: this was a good investment for the Profibus newcomers. Dietz: „Companies can save on trainings, but this will backfire during operational maintenance.“

### Time is money

The experiences of this pilot project show that there is savings potential in commissioning. „We

had to do a lot of things several times, since there were modifications and adaptations ongoing all the time“, explains Sven Seintsch of Infracerv Höchst Technik. Changes during the planning process are daily business in pharma projects. „In that respect the advantage of fieldbus has to be estimated even higher since the user gets much more flexible“, says Dietz. „The first plant showed how this reduced project time can be used sensible. Detailed planning of Process C&I can start later, is installed later in the plant and thus saves a lot on modifications since the production process is already stable“, confirms Bartscheit. The logical consequence: the plant can go into operation earlier and this means money in the pocket.

At no time any of the hardware problems endangered the faster commissioning. The Profibus software worked without problems, too. The same the project members could not state for the FDT/DTM software (see box). „The commissioning of the Profibus lines went without problems in terms of the hardware. As an average it took only one day for 30 devices. One more advantage, compared to older times, is that marshalling faults do not occur“, Seintsch sums it up. This is seen as a real success by the fieldbus experts. Bartscheit: „Ultimately a lot of apprehensions proved wrong and we searched for problems which simply did not exist.“

Once the teething problems are solved and the users are familiar with the new technology, its benefit will be increased even more. Realization of the many chances offered by fieldbus technology requires a certain experience. „At the moment everybody is happy when the bus is working“, says Seintsch. „Aspects such as process optimization, diagnosis and maintenance are still some way out. Only after the technology is established the user will start to pay attention to the mass of additional information he gets for free by the bus.“ In the expert's opinion the discussion on added value of fieldbus is just starting.

All concur in one more point: The new Profibus plant confirms the predication of FuRIOS regarding faster commissioning and more simple installation. Fieldbus technology and fieldbus barrier concept have definitely proven their suitability for daily use, and this gets around. At present there are two major projects and one smaller one with fieldbus technology in Industriepark



Höchst at Frankfurt, Germany. Furthermore there are many more ongoing projects at other locations of the former Höchst company. "The time is ripe for digital technology. If we want to get out of this antiquated 4 mA ... 20 mA device technology we desperately need the fieldbus", says

fieldbus-fan Tauchnitz. „People who are not brave enough by now cannot be helped. At this location there will be no new plant designed without fieldbus, this is certain!"

*Dr. Christine Eckert, journalist*

### FDT/DTM

*FuRIOS and the considerations regarding Ketek are focused on the theme of fieldbus only. The study did not cover field device engineering and therefore does not give any assessment on its advantages or disadvantages. For the first time, the integration of the 15 different device types was done directly in the control system. The project team decided to use the FDT/DTM Technology as integration tool. Since this technology is rather new it raised several questions all through the project. It required a lot of persistence and competence of all involved persons to master these obstacles. At first glance this seems to be contradictory to the statement 'fieldbus is ready for practical use'. However, at a closer look one sees that device engineering is a completely different subject, independent of fieldbus.*

### Project scope

*Control system ABB Melodie*

- 11 process near components, DCS's*
  - 22 Profibus DP segments*
  - 250 Drives and Converters*
  - 200 Profibus PA segments*
  - 1600 Profibus PA devices*
  - 1230 Transducers,*
  - 160 Positioners*
  - 190 Valve Boxes,*
  - 20 Sensor Boxes*
  - 15 different device types manufactured by ABB, Endress+Hauser, Krohne, Knick, Pepperl+Fuchs, Samson, Vega*
  - 50 Segment Couplers Pepperl+Fuchs SK2*
  - 470 Fieldbus Barriers Pepperl+Fuchs FieldBarrier*
- Field device engineering FDT/DTM technology in Control System*



# Less handicaps in explosion hazardous areas

## Practice-oriented Power Supply Concepts for fieldbus reduce previous limitations

The first practical experiences with the comprehensive use of fieldbus technology in major automated production plants have been presented at the 2004 general assembly of NAMUR, the Association of Users of Process Control Technology. The decisive factor for the positive appraisal was the utilization of modern power supply concepts which eliminate fieldbus technology's previous limitations in explosion hazardous areas. High Power Trunk Concepts for Ex-zones 1 and 2 allow to get the optimum advantage of fieldbus technology while maintaining the benefits of explosion protection by means of energy limitation.

THOMAS KASTEN

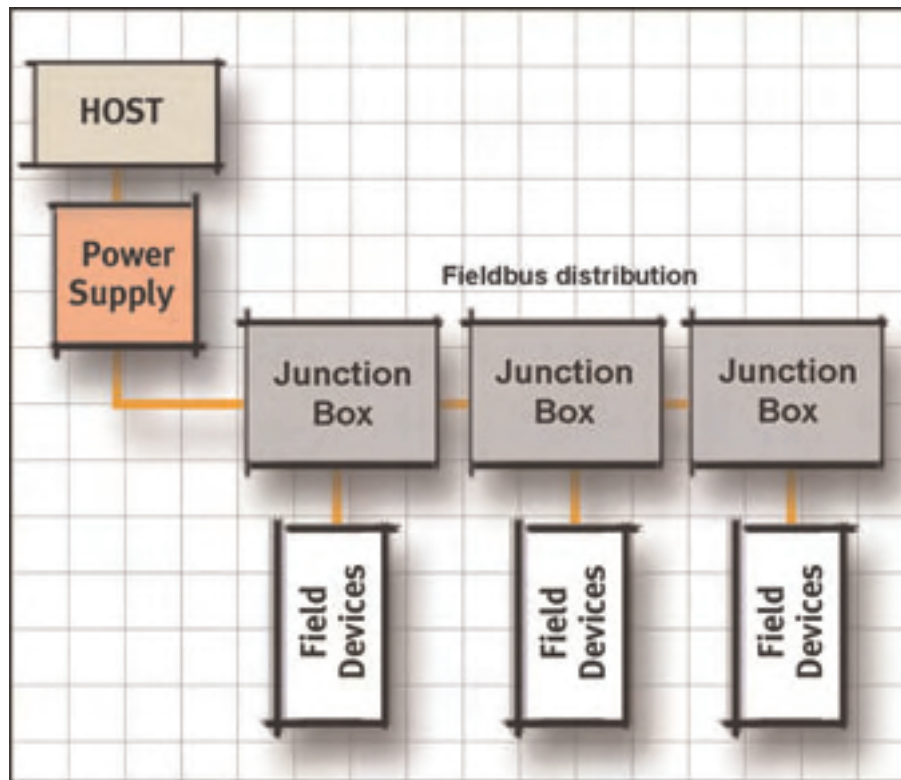

Fig. 1: Fieldbus topology in line structure with trunk and spurs



Dipl.-Wirtsch.-Ing. Thomas Kasten is responsible for the product group FieldConnex® in the Marketing Department of Pepperl+Fuchs GmbH. Prior to that he held several positions outside of Germany, covering technical marketing and service. He is a member of the Marketing Working Group of the PROFIBUS User Organisation and of the European Marketing Council of the Fieldbus Foundation.

**Contact**  
Tel. +49 621 776-2222  
pa-info@de.pepper-fuchs.com



After long years of testing and theoretical analyses, plant control by fieldbus technology is starting to gain success in process automation. At the NAMUR general assembly in November 2004 several presentations described and positively appraised the first practical experiences in using PROFIBUS PA as well as FOUNDATION Fieldbus H1 in major production plants. A basic prerequisite for this acceptance is the elimination of the limitations which restricted the use of fieldbus technology in explosion hazardous environments up to now. This was achieved by the fieldbus barrier concept which had been evaluated theoretically two years ago in the FuRIOS Study and now sees its practical use

in the first plants. A good example is the Ketek plant of Aventis Pharma Deutschland which produces two preliminary substances of the novel antibiotic Ketek by means of two production lines comprising a total of 1,600 PROFIBUS PA devices.

### Basics of fieldbus use in explosion hazardous environments

What's so special about this fieldbus barrier concept? To answer this question one has to consider the conditions set in the fieldbus standard IEC 61158-2 as well as the requirements of explosion protection in Zone 1/Class I, Div. 1 by means of intrinsic safety according to IEC 60079-27. The fieldbus standard allows up to 32 devices at one segment

and requires for each field device a minimum working voltage of 9 V DC and a minimum current consumption of 10 mA. The digital communication signals are transmitted in Manchester II encoding by means of a  $\pm 9$  mA amplitude. All considerations are based on the reference fieldbus cable Type A, which is a shielded twisted pair cable with conductor cross-sections of  $0.8 \text{ mm}^2$  (AWG18) and a loop resistance of 44 Ohm/km. This cable transmits the digital communication as well as the supply power for the field devices. In order to disconnect individual devices from the bus without impairing the operation of the other devices each one should be connected to one central main line (trunk) by means of individual drop lines. Fig. 1 shows such a recommended line structure with a trunk and several connection spurs. The term 'Power Supply' summarizes the specific fieldbus power supply units which are mandatory to combine the digital signal of the fieldbus host with the direct current for device supply. These Power Supplies are available in several versions and various output current levels. Based hereon and the actual power consumption of the connected devices the maximum cable length of a fieldbus segment is calculated, keeping in mind that the device farthest away from the Power Supply has to meet the above mentioned minimum values. The maximum total cable length of trunk plus all spurs is 1,900 m, according to IEC 61158-2. 'Intrinsic Safety' EEx i achieves the explosion protection by limiting the energy in the segment so that a spark powerful enough to ignite the surrounding atmosphere cannot develop. This allows live work at the devices during operation without special safety precautions. The other side of the coin is a significant reduction of the supply current to 70 mA for EEx ia applications which results in major limitations regarding cable length and possible number of devices. Consequently the fieldbus was not attractive for explosion hazardous environments up to now. Furthermore the required confirmation of

intrinsic safety is a rather complex calculation when using the original Entity model. The Fieldbus Intrinsically Safe Concept FISCO reduces this confirmation to the comparison of only a few parameters and allows the slightly higher power supply of 100 mA, however paying for these advantages by increased requirements on the device technology and reduced maximum total cable length.

### Advantages of the fieldbus barrier concept

Starting point of the development of this concept was the evaluation at

which elements of a fieldbus segment repair and maintenance work during operation might be necessary. These are the field devices and their connection lines which should consequently be installed in EEx i. The need for live work at the passive wiring of trunk and fieldbus distribution modules is extremely unlikely, these can be installed using the explosion protection method 'increased safety' EEx e resp. Div. 2 wiring methods. Thus the passive wiring is not subjected to energy limitation. State-of-the-art fieldbus barriers such as the FieldConnex® FieldBarrier are designed for connecting

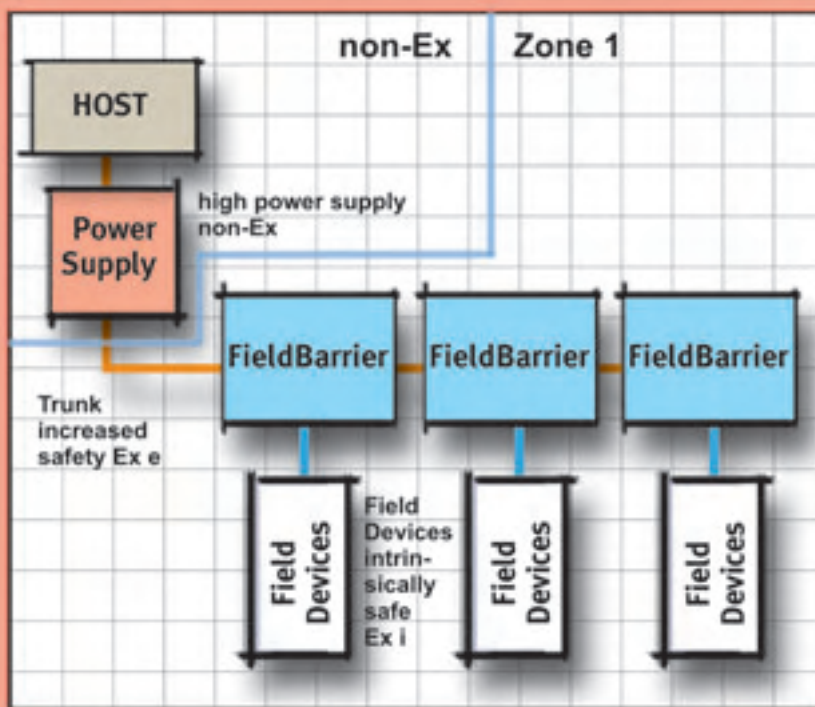

Fig. 2: Topology for Zone 1 according to the fieldbus barrier concept

and daisy-chaining the trunk in EEx e, can be installed in Zone 1 resp. in Class I, Div. 2 with spurs reaching into Div. 1, and thus allow to lead a high supply power into the explosion hazardous area. When using modern Power Supplies such as the modules of the FieldConnex™ system, this could be 400 mA with PROFIBUS PA and up to

1 A with FOUNDATION Fieldbus H1, significantly more than under EEx i conditions. Consequently this way of fieldbus wiring is often described as ‚High-Power Trunk Konzept‘. The four outputs of the FieldBarrier deliver 40 mA EEx ia IIC and thus allow the connection of intrinsically safe field devices with all their advantages, see fig. 2. The

confirmation of intrinsic safety is reduced to the respective device and its connection line and can be conducted according to Entity as well as, simplified, according to FISCO. Even more, now the max. cable length of 1,900 m as defined in IEC 61158-2 for non-Ex areas is possible in Zone 1, too, with full advantage of the max. spur length of 120 m.

### Protection against failures due to short-circuit or overvoltage

The big advantage of fieldbus technology is the connection of several sensors and actuators to one and the same cable, whilst with conventional point-to-point wiring each device needs its individual cable to the process-near component in the safe area. Therefore a short-circuit would impair only that one device. With fieldbus, however, all devices at the segment would stop communicating. To prevent that each output of the FieldBarrier is short-circuit current limited to 45 mA, only the faulty spur will go offline. Since the remaining devices in the segment keep communicating an easy and fast fault localisation in the control system is guaranteed. Furthermore each module of the FieldConnex® system is protected against functional overvoltages. For enhanced protection, e.g. by implementing a lightning protection zones concept according to IEC 61312-1, there are surge protection modules specifically optimized for fieldbus technology available.

### High Power Trunk Concepts for Zone 2 / Class I, Div. 2

A fieldbus segment for Zone 2 can be designed similar to the fieldbus barrier concept. Since the requirements in regard to explosion protection are not as stringent FieldConnex® Segment Protectors are used instead of FieldBarriers (fig. 3). For the trunk the explosion protection method, non sparking' EEx nA is applied and allows to lead high power into Zone 2. The Segment Protectors are certified according to EEx nA[L] and can be installed in Zone 2 / Class I, Div. 2. Each output is energy limited according to EEx nL IIC, the output current is 40 mA, the output voltage max. 31 V. Furthermore each output is individually short-circuit current limited to 45 mA. Field devices with appropriate certification for Zone 2 as well as intrinsically safe devices can be connected. The evaluation of the safety parameters

follows the Entity concept but is significantly simplified since each spur is cal-

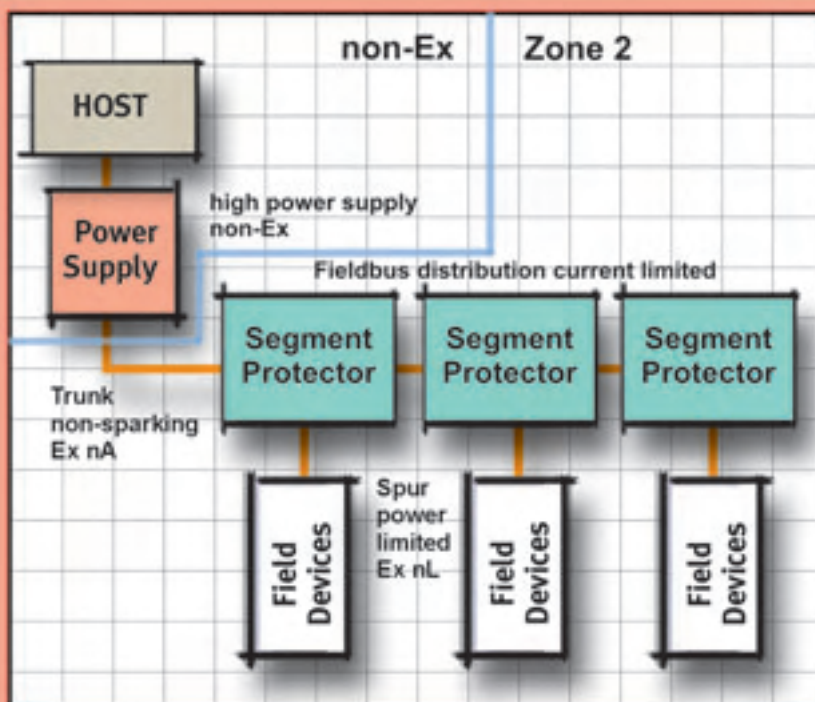

Fig. 3: High Power Trunk concept for Zone 2

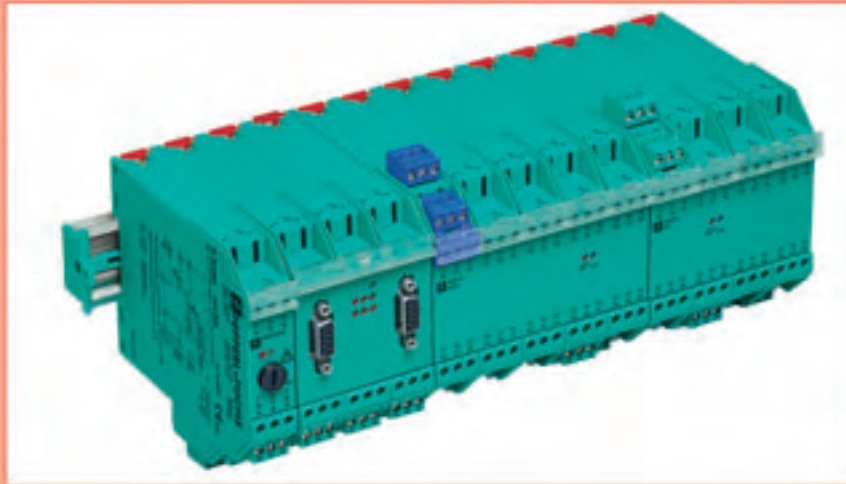

Fig. 4: FieldConnex® Segment Coupler with media redundant PROFIBUS DP connection and Power Link Modules for 2 PROFIBUS PA segments

culated individually. For the supply of today's typical intrinsically safe devices the FieldConnex® Power Hub system offers modules with a voltage limitation to max. 23 V. By means of Power Hub modules limited to 17 V segments following the Fieldbus Non-Incendive Concept FNICO according to IEC 60079-27 Ed. 1 can be installed. FNICO is an adaptation of FISCO to Zone 2, however today there are only a few FNICO certified field devices available on the market. Furthermore the voltage limitation reduces the possible total cable length and number of fieldbus

devices. As the only benefit the confirmation of the safety parameters by calculation can be omitted. In future the requirements for these voltage limitations will dwindle since more and more field devices certified according to EEx nL with  $U_i > 32$  V are appearing on the market. Thus the voltage limitation of the Segment Protector is sufficient and the advantages of the High-Power Trunk Concept can be fully realized.

### Fieldbus Power Supplies

High-Power Trunk Concepts for Zone 1 and Zone 2 allow to transmit high sup-

ply power into explosion hazardous areas. On top of the above described function of merging digital fieldbus signal and supply current modern Fieldbus Power Supplies offer far more features for optimization of fieldbus communication and plant availability. Modular designed Segment Couplers (fig. 4) convert the RS485 transmission physics of PROFIBUS DP to the IEC 61158-2 physics of PROFIBUS PA. Various Gateway Modules are available. To each Gateway several Power Link Modules can be connected, each one supplying one fieldbus segment with up to 400 mA. The Segment Coupler's maximum configuration allows the design of 20 PA Segments according to the High-Power Trunk Concept with a media redundant PROFIBUS DP connection to the Profibus master. The FieldConnex® Power Hub (fig. 5) is a modular system, too, and allows the connection of up to four FOUNDATION Fieldbus H1 segments to one common motherboard. Several variants with host-specific system connectors are available. Depending on the requirements on plant availability the motherboards can be equipped with single or redundant electronic modules. The novel CREST technology stabilizes the fieldbus communication by minimizing the disturbances due to noise and suppressing the resonances in the system. Very high requirements on the isolation of fieldbus segments can be met by using modules with galvanic isolation. Diagnostic modules allow monitoring of various functional parameters of Power Hub and fieldbus segment. Furthermore some variants of the Power Hub feature a novel short-circuit current limitation of the connection line to the host.

### Perspective

The first practical experiences with comprehensive fieldbus applications in major production plants are rather encouraging. The presentations at the NAMUR general assembly concluded with the statement: "Fieldbus is the right path to future". However, the users still handed over a list of wishes to manufacturers and fieldbus organisations which was gladly accepted. For example the fieldbus barrier concept, since a few month, is explicitly mentioned in the official Application Guide of the Fieldbus Foundation. In the near future design and calculation of High-Power Trunk Concepts will be facilitated by new tools such as the recently updated FieldConnex® Segment Checker software tool.



Fig. 5: FieldConnex® Power Hub on Motherboard for four FOUNDATION Fieldbus H1 segments, redundant configuration

HOST



... connecting Fieldbus Power and Knowledge

### Junction Boxes/Segment Protectors

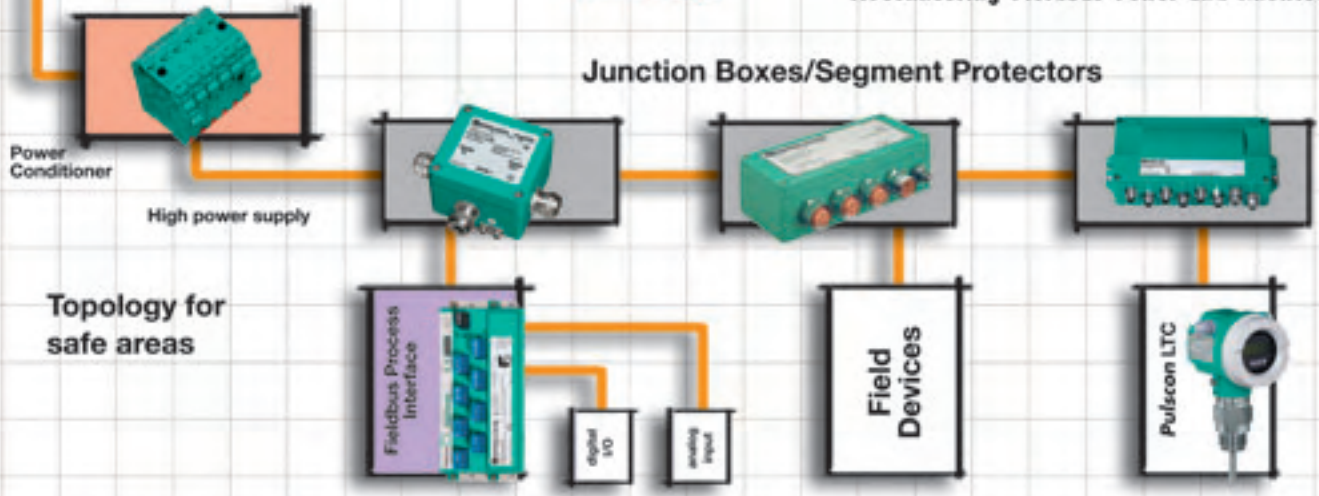

Topology for safe areas

### Segment Protectors

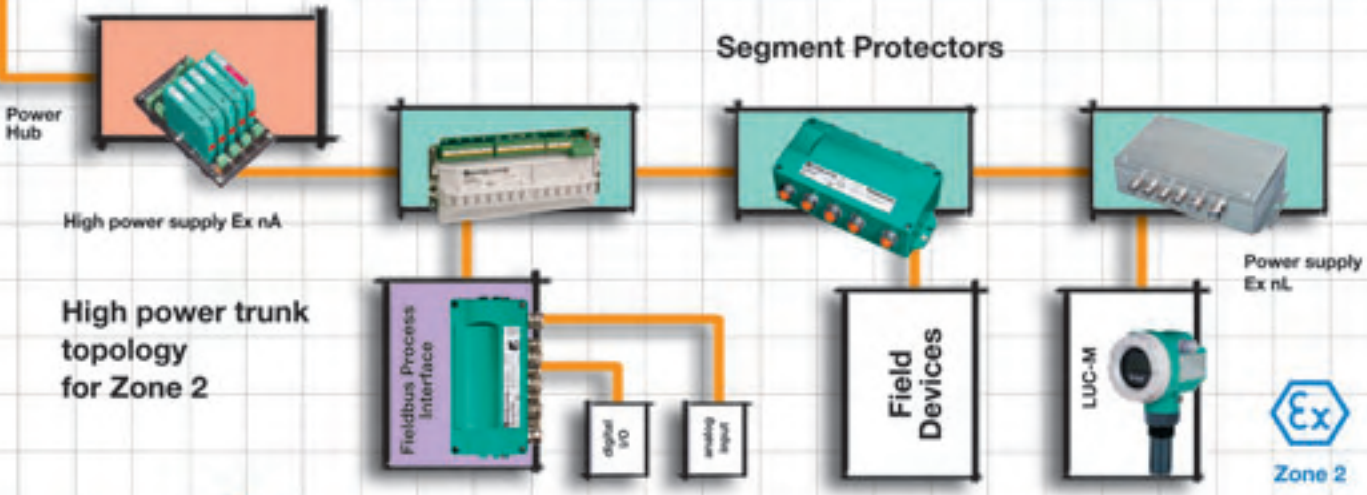

High power trunk topology for Zone 2

### FieldBarriers

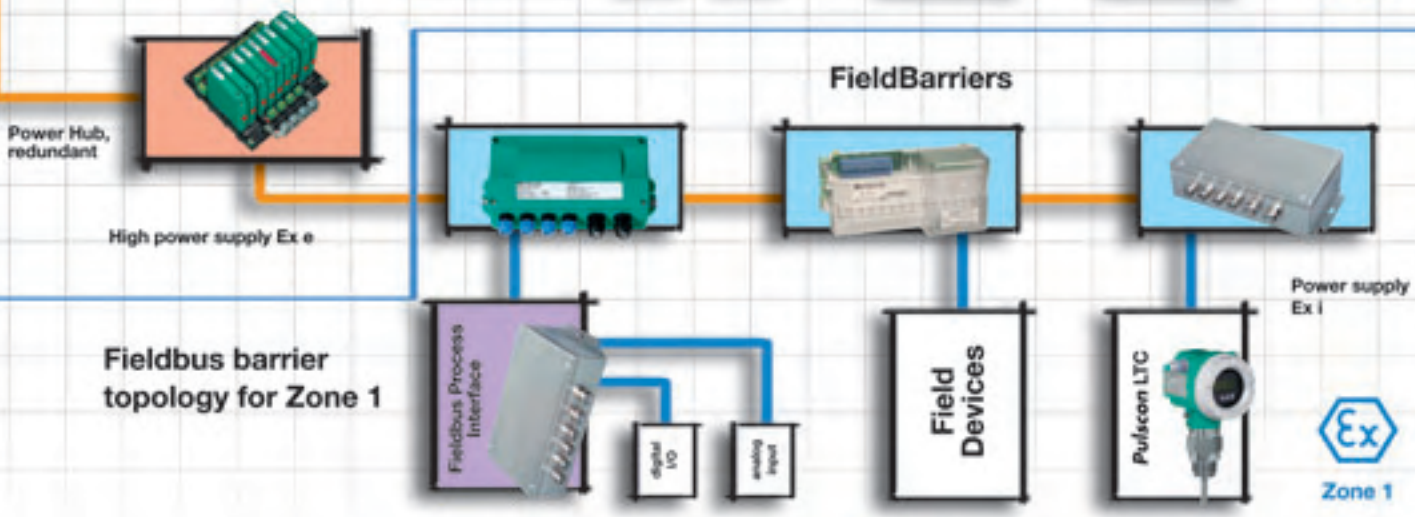

Fieldbus barrier topology for Zone 1

[www.fieldconnex.info](http://www.fieldconnex.info)



# FOUNDATION FIELDBUS H1 HIGH-POWER TRUNK TOPOLOGIES

## High-Power Trunk Topologies for FOUNDATION Fieldbus H1

The FuRIOS study recommends the application of fieldbus technology all throughout process production plants. Only in this way the advantages of this future oriented technology can be realized to the fullest extend. The basis is a topology concept which neutralizes the previous limitations of fieldbus application in explosion hazardous areas. These High-Power Trunk Topologies can easily be designed by means of a comprehensive Fieldbus Installation System such as FieldConnex®. Furthermore FieldConnex® offers all modules and protection functionalities to ensure efficient plant operation with high availability over many years. The experiences from plants planned and put into operation based on these installation concepts confirm the expectations of FuRIOS.

A High-Power Trunk Topology consists of several basic functional groups. The FieldConnex® System offers for each functionality the appropriate, interoperable modules.

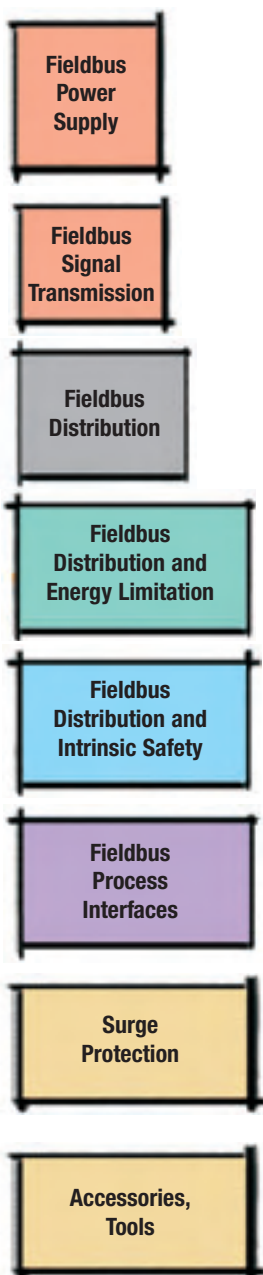
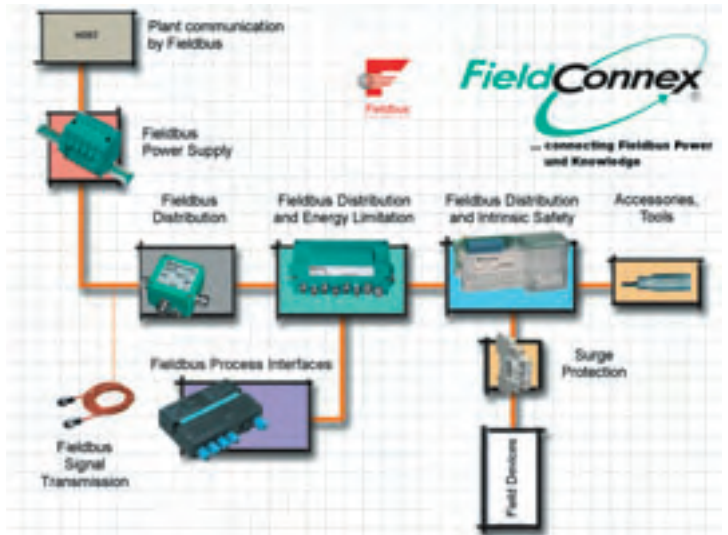

### Fieldbus Power Hub

- Modular Power Supply System meeting the requirements of all applications and host systems
- High output current and several voltages for maximum number of devices in various explosion protection concepts
- Sophisticated isolation, redundancy and diagnosis concepts guarantee optimum plant availability
- Novel CREST technology minimizes signal distortions and ensures safe communication

### Fieldbus Cables and Cord Sets

- Fieldbus cable type A according to fieldbus installation guidelines for optimum signal transmission
- Safe operation due to variants for all environmental conditions
- Versions with various plug connectors allow fast and fault-free installation

### Junction Box

- Simple, individual connection of field devices to the fieldbus segment
- Quick and efficient fault localisation and rectification
- High flexibility due to various connection types and sturdy housings for harsh environments

### Segment Protector

- Explosion protection in Zone 2 / Class I, Div. 2 by energy limitation of the outputs
- Increased plant reliability due to short-circuit and overload protection
- High flexibility due to various connection types and sturdy housings for harsh environments

### FieldBarrier

- Explosion protection in Zone 1 / Class I, Div. 1 by intrinsically safe outputs according to FISCO and Enty
- Increased plant reliability due to short-circuit and overload protection
- Various shielding options guarantee minimization of signal distortions
- High flexibility due to various connection types and sturdy housings for harsh environments

### Temperature Multi-Input, Valve Coupler, Fieldbus-Pneumatic Interface

- Easy integration of almost all conventional signals into fieldbus communication
- Power supply of the interfaces intrinsically safe via the fieldbus cable
- Integrated diagnostic functions for sensors and connection cables
- Direct actuation of solenoid and pneumatic valves

### Surge Protector

- Protection of fieldbus host and instrumentation against voltage surges and lightning strikes
- Variants for various environmental conditions and explosion protection concepts
- Modular system with additional functionalities allow efficient plant operation

### Segment Checker Design Software, Documentation, Services

- Efficient planning of optimized fieldbus topologies by 'Drag and Drop' on [www.segmentchecker.com](http://www.segmentchecker.com)
- Comprehensive installation guidelines and detailed information on all FieldConnex® modules on [www.fieldconnex.info](http://www.fieldconnex.info)
- Consulting services and support with fieldbus projects and specific system solutions by your local Pepperl+Fuchs representative

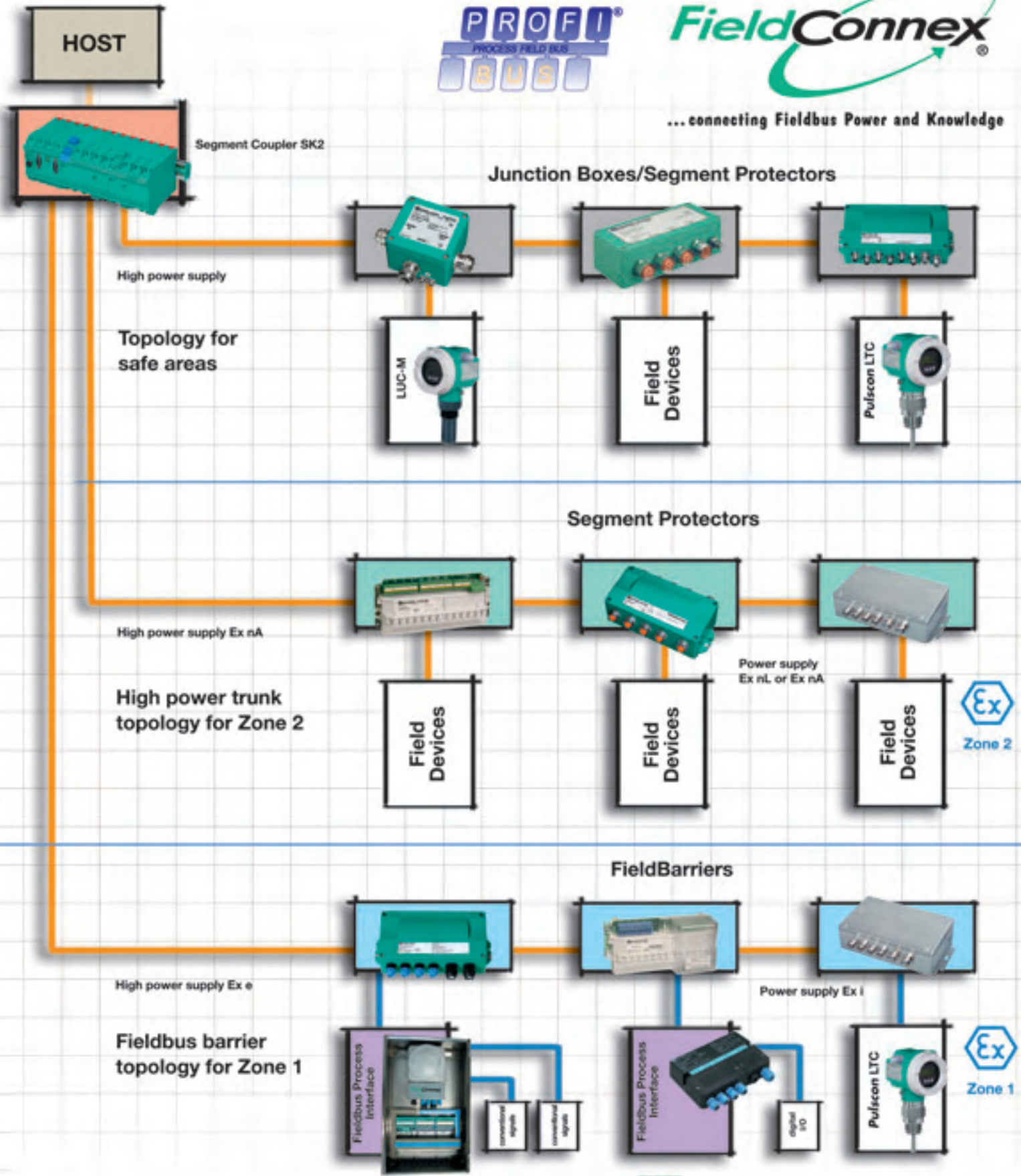

## High-Power Trunk Topologies for PROFIBUS PA

The FuRIOS study recommends the application of fieldbus technology all throughout process production plants. Only in this way the advantages of this future oriented technology can be realized to the fullest extend. The basis is a topology concept which neutralizes the previous limitations of fieldbus application in explosion hazardous areas. These High-Power Trunk Topologies can easily be designed by means of a comprehensive Fieldbus Installation System such as FieldConnex®. Furthermore FieldConnex® offers all modules and protection functionalities to ensure efficient plant operation with high availability over many years. The experiences from plants planned and put into operation based on these installation concepts confirm the expectations of FuRIOS.

A High-Power Trunk Topology consists of several basic functional groups. The FieldConnex® System offers for each functionality the appropriate, interoperable modules.

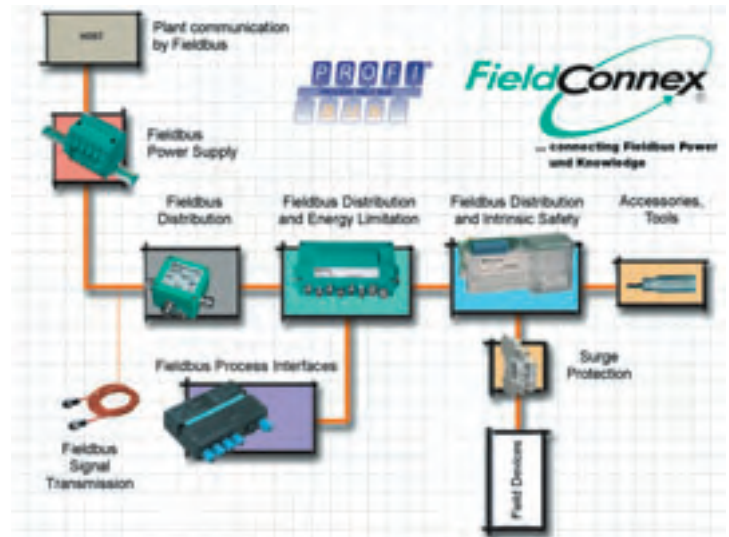

### Fieldbus Power Supply

#### Segment Coupler

- Adaptation of all PROFIBUS DP bit rates to PROFIBUS PA
- High power output for maximum number of devices per segment
- Modular concept allows flexible plant design
- Maximum safety due to galvanic isolation

### Fieldbus Signal Transmission

#### Fieldbus Cables and Cord Sets

- Fieldbus cable type A according to fieldbus installation guidelines for optimum signal transmission
- Safe operation due to variants for all environmental conditions
- Versions with various plug connectors allow fast and fault-free installation

### Fieldbus Distribution

#### Junction Box

- Simple, individual connection of field devices to the fieldbus segment
- Quick and efficient fault localisation and rectification
- High flexibility due to various connection types and sturdy housings for harsh environments

### Fieldbus Distribution and Energy Limitation

#### Segment Protector

- Explosion protection in Zone 2 / Class I, Div. 2 by energy limitation of the outputs
- Increased plant reliability due to short-circuit and overload protection
- High flexibility due to various connection types and sturdy housings for harsh environments

### Fieldbus Distribution and Intrinsic Safety

#### FieldBarrier

- Explosion protection in Zone 1 / Class I, Div. 1 by intrinsically safe outputs according to FISCO and Entity
- Increased plant reliability due to short-circuit and overload protection
- Various shielding options guarantee minimization of signal distortions
- High flexibility due to various connection types and sturdy housings for harsh environments

### Fieldbus Process Interfaces

#### Valve Coupler, Sensor Interface, Fieldbus-Pneumatic Interface, MiniRIO

- Easy integration of almost all conventional signals into fieldbus communication
- Power supply of most interfaces intrinsically safe via the fieldbus cable
- Integrated diagnostic functions for sensors and connection cables
- Direct actuation of solenoid and pneumatic valves

### Surge Protection

#### Surge Protector

- Protection of fieldbus host and instrumentation against voltage surges and lightning strikes
- Variants for various environmental conditions and explosion protection concepts
- Modular system with additional functionalities allow efficient plant operation

### Zubehör, Hilfsmittel

#### Segment Checker Design Software, Documentation, Services

- Efficient planning of optimized fieldbus topologies by 'Drag and Drop' on [www.segmentchecker.com](http://www.segmentchecker.com)
- Comprehensive installation guidelines and detailed information on all FieldConnex® modules on [www.fieldconnex.info](http://www.fieldconnex.info)
- Consulting services and support with fieldbus projects and specific system solutions by your local Pepperl+Fuchs representative

# FAX answer to +49 621 / 776 1400

Please send to:  
 Pepperl+Fuchs GmbH  
 Product Marketing, Mr. Thomas Kasten

or by e-mail: [info@de.pepperl-fuchs.com](mailto:info@de.pepperl-fuchs.com)

Please state your mailing address:

Company: .....  
 Name: Mr. / Mrs. ....  
 First name: .....  
 Department: .....  
 Street: .....  
 Zip code / City: .....  
 Country / State: .....  
 Phone: .....  
 Fax: .....  
 e-mail: .....

Dear Madame / Sir,

are you interested in more information on the future oriented fieldbus technology in process automation?

Then please check the requested information. We will be happy to forward these documents to you.

- FuRIOS 2 – the complete updated compendium of the user study ‚Fieldbus and Remote I/O System Comparison’ with additional information, insider interviews and practical experiences
- Information on PROFIBUS PA
- Information on FOUNDATION Fieldbus H1
  
- Please put me on the Pepperl+Fuchs fieldbus information distribution list.  
 I will automatically receive the newest information on fieldbus technology and FieldConnex until further notice.
- I currently work on fieldbus projects. Please contact me by phone.

Are you interested in further product lines of Pepperl+Fuchs?

Please name them below so we can send you the appropriate information:

- Pepperl+Fuchs PA Highlights – the complete outline of all product lines for process automation
- Conventional Interface Modules
- Remote I/O Systems
- Systems for HART Communication
- Field devices for level control
- Pepperl+Fuchs EXTEC – Controlling and monitoring in hazardous areas
- Pepperl+Fuchs sensors and systems for factory automation

.....  
 (Date)

.....  
 (Signature)

## SIGNALS FOR THE WORLD OF AUTOMATION

### **Pepperl+Fuchs GmbH**

#### **Worldwide Headquarters**

Pepperl+Fuchs GmbH · Königsberger Allee 87  
68307 Mannheim · Germany  
Tel. +49 621 776-0 · Fax +49 621 776-1000  
<http://www.pepperl-fuchs.com>

#### **USA Headquarters**

Pepperl+Fuchs Inc. · 1600 Enterprise Parkway  
Twinsburg, Ohio 44087 · Cleveland-USA  
Tel. +1 330 4253555 · Fax +1 330 425 46 07  
**e-mail: [sales@us.pepperl-fuchs.com](mailto:sales@us.pepperl-fuchs.com)**

#### **Asia Pacific Headquarters**

Pepperl+Fuchs Pte Ltd. · P+F Building  
18 Ayer Rajah Crescent · Singapore 139942  
Tel. +65 67799091 · Fax +65 68731637  
**e-mail: [sales@sg.pepperl-fuchs.com](mailto:sales@sg.pepperl-fuchs.com)**

**The respective authors take responsibility for the contents of the articles.**

Subject to reasonable modifications due to technical advances.

Copyright PEPPERL+FUCHS · Printed in Germany · Part. No. 127 960 03/05 01