



Fieldbus Foundation™
Freedom to Choose. Power to Integrate.



Technical Overview

FOUNDATION™ fieldbus

“Freedom to Choose. Power to Integrate.”

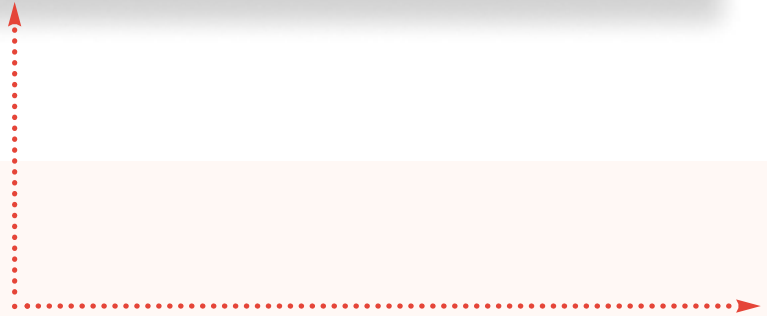

Compliments of:

The Fieldbus Foundation

FOUNDATION Fieldbus Technical Overview

FD-043 Revision 3.0

This overview has been prepared to aid understanding of the technical aspects of FOUNDATION fieldbus.

The booklet begins with a brief summary of fieldbus benefits followed by the goals, principles and organization of the not-for-profit Fieldbus Foundation.

The main portion of the booklet is devoted to the definition and explanation of key technical concepts inherent in FOUNDATION fieldbus technology.

I sincerely hope this information proves useful to you. Please contact the Fieldbus Foundation if you need additional information about this exciting new technology.

David A. Glanzer
Director of Technology Development

For additional information please contact:

Fieldbus Foundation
9005 Mountain Ridge Drive
Bowie Bldg., Suite 200
Austin, TX 78759-5316
USA

Voice: (512) 794-8890
Fax: (512) 794-8893

Visit our World Wide Web Site:
<http://www.fieldbus.org>

DISCLAIMER OF WARRANTIES

This document is provided on an "as is" basis and may be subject to future additions, modifications, or corrections. The Fieldbus Foundation hereby disclaims all warranties of any kind, express or implied, including any warranty of merchantability or fitness for a particular purpose, for this document. In no event will the Fieldbus Foundation be responsible for any loss or damage arising out of or resulting from any defect, error or omission in this document or from anyone's use of or reliance on this document.

Table of Contents



1.0	WHAT IS FOUNDATION FIELDBUS?	1
1.1	H1 Benefits	1
1.1.1	More Data Available	2
1.1.2	Expanded View of the Process and Instruments	2
1.1.3	Reduction in System Hardware	2
1.1.4	Wiring Savings	3
1.2	HSE Benefits	3
1.2.1	High Performance	3
1.2.2	Subsystem Interoperability	3
1.2.3	Function Blocks	3
1.2.4	Control Backbone	3
1.2.5	Standard Ethernet	3
2.0	WHO IS THE FIELDBUS FOUNDATION?	4
2.1	Organization	4
2.1.1	Members	4
2.1.2	Board of Directors	4
2.1.3	President	4
2.1.4	End User Advisory Council	4
2.1.5	End User Councils	4
2.1.6	Quality Director	5
2.1.7	Executive Committee	5
2.1.8	Technical Teams	5
2.1.9	Marketing Teams	5
2.1.10	Member Support	5
3.0	FOUNDATION FIELDBUS TECHNOLOGY	5
3.1	User Application – Blocks	6
3.1.1	Resource Block	6
3.1.2	Function Block	6
3.1.3	Transducer Blocks	7
3.1.3.1	Supporting Objects	7
3.1.4	Fieldbus Device Definition	9
3.2	Function Block Scheduling	9
3.2.1	Application Clock Distribution	10
3.2.2	Device Address Assignment	10
3.2.3	Find Tag Service	10
3.3	Device Descriptions	11
3.3.1	Device Description Tokenizer	11
3.3.2	Device Description Services (DDS)	12
3.3.3	Device Description Hierarchy	12
3.3.4	Capability Files	13



3.4 H1 Communication Stack	14
3.4.1 The Data Link Layer (DLL)	14
3.4.1.1 Device Types	15
3.4.1.2 Scheduled Communication	15
3.4.1.3 Unscheduled Communication	16
3.4.1.4 Link Active Scheduler Operation	16
3.4.1.4.1 CD Schedule	16
3.4.1.4.2 Live List Maintenance	16
3.4.1.4.3 Data Link Time Synchronization	17
3.4.1.4.4 Token Passing	17
3.4.1.4.5 LAS Redundancy	17
3.4.2 System Management	17
3.4.3 Fieldbus Access Sublayer (FAS)	17
3.4.3.1 Client/Server VCR Type	17
3.4.3.2 Report Distribution VCR Type	18
3.4.3.3 Publisher/Server VCR Type	18
3.4.3.4 Summary of VCR Types	18
3.4.4 Fieldbus Message Specification (FMS)	18
3.4.4.1 Virtual Field Device (VFD)	19
3.4.4.2 FMS Services	19
3.4.4.2.1 Context Management Services	19
3.4.4.2.2 Object Dictionary Services	19
3.4.4.2.3 Variable Access Services	19
3.4.4.2.4 Event Services	19
3.4.4.2.5 Upload/Download Services	20
3.4.4.2.6 Program Invocation Services	20
3.4.4.3 Message Formatting	20
3.4.4.4 Protocol Behavior	21
3.5 Physical Layer (31.25 kbit/s)	21
3.5.1 31.25 kbit/s Fieldbus Signaling	22
3.5.2 31.25 kbit/s Fieldbus Wiring	23
3.6 HSE Communication Stack	24
3.6.1 HSE Device Types	24
3.6.1.1 HSE Device	24
3.6.1.2 Linking Device	24
3.6.1.3 Gateway Device	24
3.6.1.4 Host Device (OPC DA Server)	24
3.6.2 Ethernet Presence	24
3.6.3 Field Device Access (FDA)	25
3.6.4 HSE System Management	25
3.6.5 HSE Network Management	25

Table of Contents



3.7 Redundancy25
3.7.1 Need for Host-Level Redundancy26
3.7.2 Media Redundancy26
3.7.3 Complete Network Redundancy26
3.7.4 Device Redundancy27
3.7.5 LAN Topologies28
4.0 SYSTEM CONFIGURATION29
4.1 System Design29
4.2 Device Configuration29
5.0 FIELD TEST SYSTEM30
5.1 Test Instrumentation30
5.2 Installation, Startup, and Operation Benefits Observed31
6.0 FEATURES SUMMARY32
7.0 REFERENCES36
8.0 DOCUMENT LIST36
9.0 ACRONYM TABLE37
10.0 TERMINOLOGY37

1.0 WHAT IS FOUNDATION™ FIELDBUS?

FOUNDATION™ fieldbus is an open, integrated total architecture for information integration.

FOUNDATION fieldbus is an all-digital, serial, two-way communication system. H1 (31.25 kbit/s) interconnects “field” equipment such as sensors, actuators and I/O. HSE (100 Mbit/s) (High Speed Ethernet) provides integration of high speed controllers (such as PLCs), H1 subsystems (via a linking device), data servers and workstations. FOUNDATION fieldbus is the only protocol with the built-in capability to distribute the control application across the network (Figure 1).

Management Information Systems (MIS), Enterprise Resource Planning (ERP), and Human Machine Interface (HMI) packages access the fieldbus information via the data services (Figure 2).

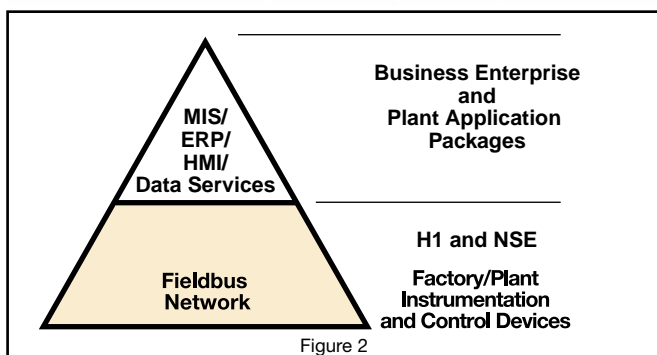
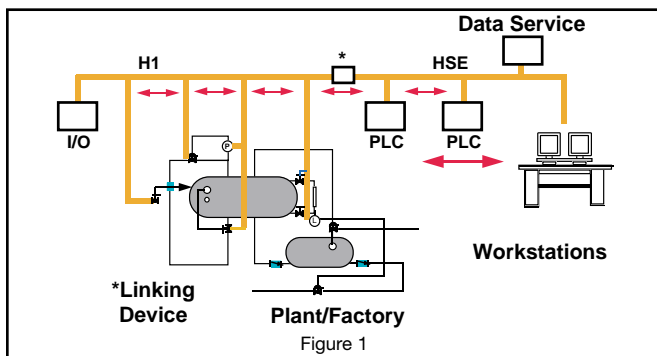

The H1 fieldbus retains and optimizes the desirable features of the 4-20 milliampere (mA) analog system such as:

- single loop integrity
- a standardized physical interface to the wire
- bus-powered devices on a single wire pair
- intrinsic safety options

In addition, FOUNDATION fieldbus enables:

- increased capabilities due to full digital communications
- reduced wiring and wire terminations due to multiple devices on one wire
- increased selection of suppliers due to interoperability
- reduced loading on control room equipment due to distribution of control and input/output functions to field devices
- connection to the HSE backbone for larger systems

1.1 H1 Benefits

Significant benefits are achieved in the control system life-cycle through the application of H1 fieldbus technology (Figure 3).

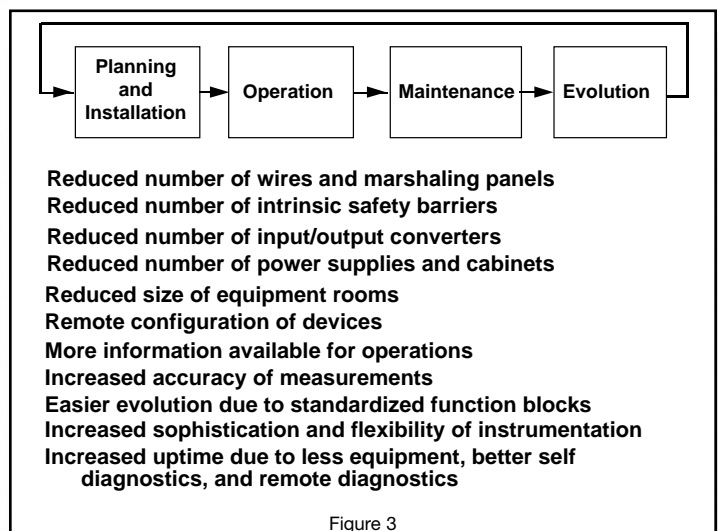

Introduction

1.1.1 More Data Available

The fieldbus allows multiple variables from each device to be brought into the control system for archival, trend analysis, process optimization studies, report generation, predictive maintenance and asset management. The high resolution and distortion-free characteristics of digital communications enables improved control capability which can increase product yields (Figure 4).

1.1.2 Expanded View of the Process and Instruments

The self-test and communication capabilities of microprocessor-based fieldbus devices help reduce downtime and improve plant safety.

Upon detection of abnormal conditions or the need for preventive maintenance, plant operations and maintenance personnel can be notified. This allows corrective action to be initiated quickly and safely (Figure 5).

1.1.3 Reduction in System Hardware

FOUNDATION fieldbus uses standard “Function Blocks” to implement the control strategy. Function Blocks are standardized automation functions. Many control system functions such as analog input (AI), analog output (AO) and Proportional/Integral/Derivative (PID) control may be performed by the field device through the use of Function Blocks (Figure 6).

The consistent, block-oriented design of function blocks allows distribution of functions in field devices from different manufacturers in an integrated and seamless manner, thus reducing risk of system failure.

Distribution of control into the field devices can reduce the amount of I/O and control equipment needed, including card files, cabinets, and power supplies.

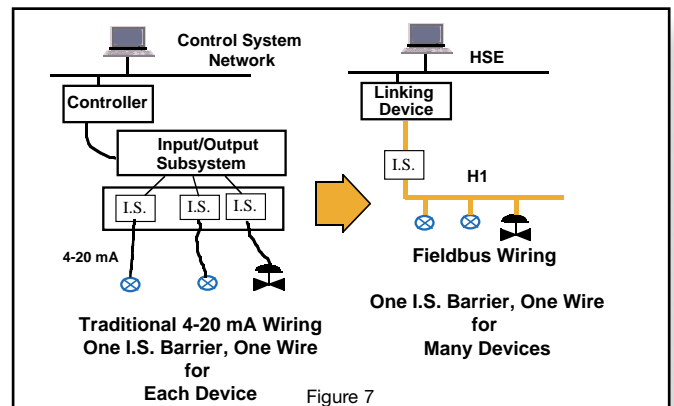
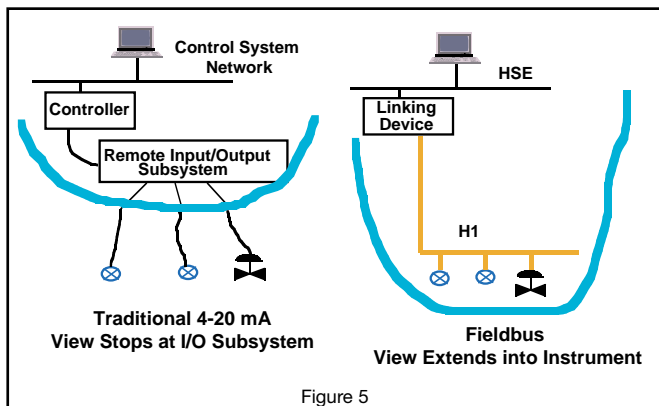
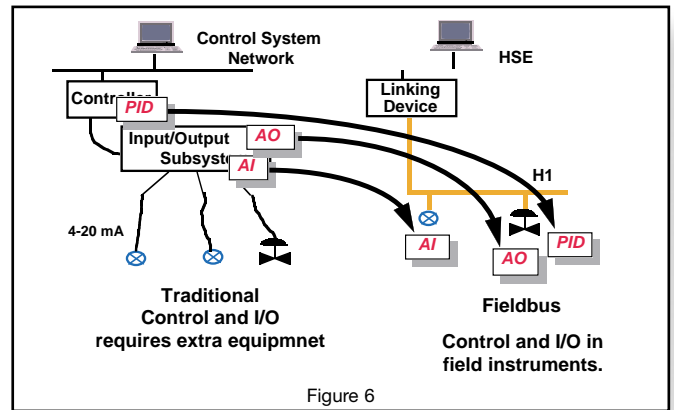
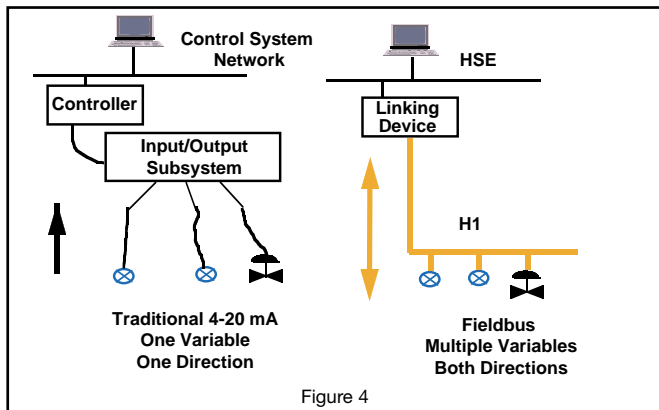



1.1.4 Wiring Savings

The H1 fieldbus allows many devices to connect to a single wire pair. This results in less wire, fewer intrinsic safety barriers, and fewer marshaling cabinets (Figure 7).

1.2 HSE Benefits

In addition to the same life cycle benefits as H1, HSE provides the control backbone that integrates all of the systems in the plant.

1.2.1 High Performance

FOUNDATION™ fieldbus enables asset management functions such as diagnostics, calibration, identification and other maintenance management operations to “mine” massive information from field devices in real-time. Asset management allows users to move to proactive maintenance which allocates resources to where they are really needed. Users employing fieldbus-based field devices and permanently connected online asset management software need HSE performance.

1.2.2 Subsystem Interoperability

Plants are comprised of a number of subsystems. With HSE, subsystems for burner management, gas chromatographs, paper web scanners, shut-down systems, compressor controls tank farms, etc., integrate easily because of the open protocol. Users can mix and match subsystems for basic control, emergency shutdown, paper quality control, advanced control and compressor control, etc., from different suppliers. Utilizing HSE, information can be accessed without custom programming. Users can select decimal subsystems to keep cost low, while at the same time reducing the configuration effort.

Data integrity, diagnostics and redundancy management are part of HSE and work seamlessly between devices from different manufacturers.

1.2.3 Function Blocks

The same FOUNDATION™ function blocks that are used in H1 devices are used in HSE devices. FOUNDATION™ fieldbus eliminates the need for proprietary programming languages. The same control strategy programming language can be used throughout the entire system.

The status associated with function block parameters is generated by field instruments based on failed sensors, stuck valves, etc., and is used for loop shut-downs, windup protection and bumpless transfer.

1.2.4 Control Backbone

HSE provides peer-to-peer communication capability. Devices communicate with each other directly without having to go through a central computer. This makes it possible to realize powerful, advanced control strategies involving variables throughout the plant without the risk of a central computer failure, further reducing risk. HSE can also bridge information between devices on different H1 networks at different ends of the plant. Thus, control can span between process cells and a plant area.

HSE replaces enterprise, control and remote-I/O networking levels, thus flattening the enterprise pyramid.

The Linking Device (LD) brings data from one or more H1 fieldbus networks directly onto the HSE backbone.

1.2.5 Standard Ethernet

Standard cable is used for HSE devices; no special tools or skills are required. Installation is simple and fast. HSE uses standard Ethernet network equipment such as switches.

Standard Commercial Off-The-Shelf (COTS) Ethernet components are made in extremely high volume. Cable, interface cards and other networking hardware are extremely low cost compared to proprietary networks. Ethernet options for media include twisted pair, fiber optics and wireless. Networking hardware is available in both commercial and industrial grades from many suppliers.

2.0 WHO IS THE FIELDBUS FOUNDATION?

Driven by their customers' needs, process control and manufacturing automation companies formed the Fieldbus Foundation to complete development of a single, open, international, and interoperable fieldbus.

The Fieldbus Foundation is an independent, not-for-profit organization based on the following principles:

- Fieldbus technology is an enabling technology; not a differentiating technology.
- Fieldbus technology is open and available to all parties.
- Fieldbus technology is based on the work of the International Electrotechnical Commission (IEC) and ISA (the international society for measurement and control).
- Fieldbus Foundation members support and work with the international and national standards committees.

2.1 Organization

The Fieldbus Foundation is organized as in Figure 8.

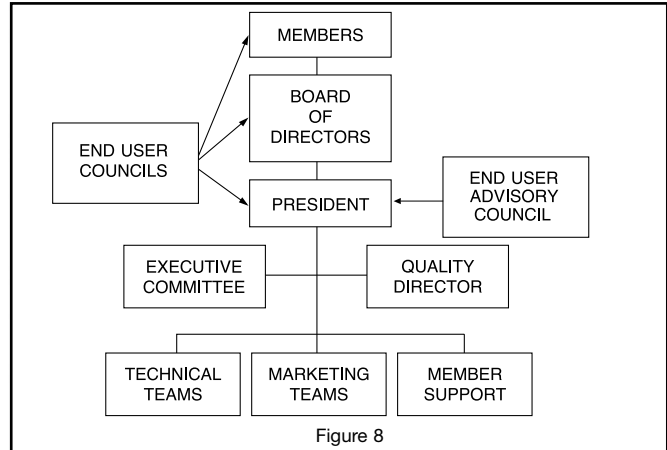

Figure 8

2.1.1 Members

The Fieldbus Foundation has over 185 member companies. These companies supply approximately 90% of the world's instrumentation and control products.

2.1.2 Board of Directors

The foundation is managed under the direction of the Board of Directors (BOD). The BOD is elected by the voting members.

2.1.3 President

The President reports to the Board of Directors, manages the day-to-day activities of the Fieldbus Foundation, and provides direction for the Executive, Technical, Marketing, and Member Support functions.

2.1.4 End User Advisory Council

The End User Advisory Council (EUAC) reports directly to the Foundation President and provides input from End Users on a worldwide basis, focusing on technical, marketing and other appropriate issues. It provides a formal mechanism for direct end user issues into the Technical Steering Committee and Board of Directory.

2.1.5 End User Councils

The End User Councils (EUC) are comprised of users of fieldbus equipment. There are EUCs in North America, Europe, Latin America and Asia-Pacific. The purpose of the EUC is to review

the activities of the foundation and provide input to help ensure the specifications meet the needs of the marketplace now and in the future, and to promote the further adoption of the technology.

2.1.6 Quality Director

The Quality Director provides overall management of the foundation's quality assurance systems.

2.1.7 Executive Committee

The Executive Committee advises the President concerning the strategic and overall operational issues of the foundation.

2.1.8 Technical Teams

The Technical Teams are responsible for the technical work of the foundation. The technical work is grouped into programs such as Specifications, Software, and Interoperability Testing. A Program Manager is responsible for each technical program.

2.1.9 Marketing Teams

The Marketing Teams are responsible for promoting FOUNDATION fieldbus and for planning and directing the foundation's products and services.

2.1.10 Member Support

Member Support is responsible for coordination and delivery of the foundation's products and services. Products and services include technical consulting

and training, newsletter printing and distribution, memberships, coordination of trade shows and field tests, product catalogs, Device Description software, and device registrations.

3.0 FOUNDATION™ FIELDBUS TECHNOLOGY

[FF-581 System Architecture*](#)

*Note: References to specific documents are noted as follows: [Document number and name.](#)

FOUNDATION fieldbus H1 technology consists of: 1) the Physical Layer, 2) the Communication "Stack," and 3) the User Application Layer. The Open Systems Interconnect (OSI) layered communication model is used to model these components (Figure 9).

The Physical Layer is OSI layer 1. The Data Link Layer (DLL) is OSI layer 2. The Fieldbus Message Specification (FMS) is OSI layer 7. The Communication Stack is comprised of layers 2 and 7 in the OSI model.

The fieldbus does not use OSI layers 3, 4, 5 and 6. The Fieldbus Access Sublayer (FAS) maps the FMS onto the DLL.

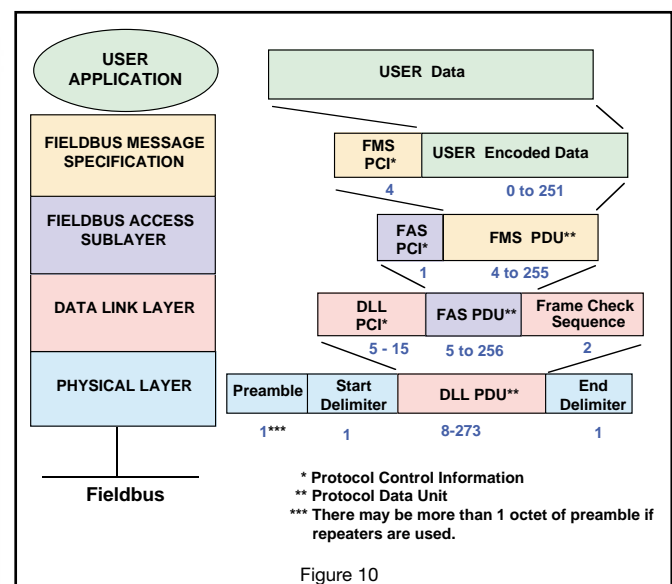
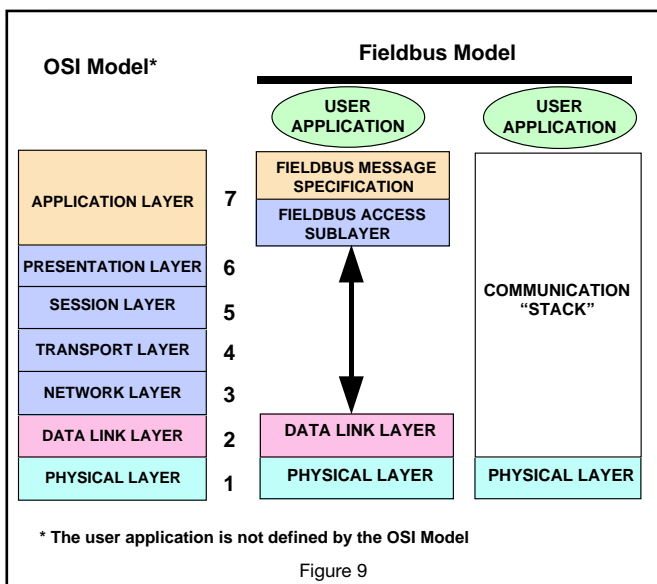

The User Application is not defined by the OSI model. The Fieldbus Foundation has specified a User Application model, significantly differentiating it from other models.

Each layer in the communication system is responsible for a portion of the message that is transmitted on the fieldbus.

Figure 10 references the approximate number of eight bit “octets” used for each layer to transfer the user data.

3.1 User Application – Blocks

- 📖 FF-890 Function Block Application Process - Part 1
- 📖 FF-891 Function Block Application Process - Part 2
- 📖 FF-892 Function Block Application Process - Part 3
- 📖 FF-893 Function Block Application Process - Part 4
- 📖 FF-894 Function Block Application Process - Part 5
- 📖 FF-902 Transducer Block Application Process - Part 1
- 📖 FF-903 Transducer Block Application Process - Part 2
- 📖 TN-003 Profile & Profile Revision

The Fieldbus Foundation has defined a standard User Application Layer based on “Blocks.” Blocks are representations of different types of application functions (Figure 11). The types of blocks used in a User Application are described in Figure 12.

Devices are configured using Resource Blocks and Transducer Blocks. The control strategy is built using Function Blocks.

3.1.1 Resource Block

The Resource Block describes characteristics of the fieldbus device such as the device name, manufacturer, and serial number. There is only one Resource Block in a device.

3.1.2 Function Block

Function Blocks (FB) provide the control system behavior. The input and output parameters of Function Blocks can be linked over the fieldbus. The execution of each Function Block is precisely scheduled. There can be many function blocks in a single User Application.

The Fieldbus Foundation has defined sets of standard Function Blocks for basic control are defined by the [FF-891 Function Block Application Process – Part 2](#) specification. These blocks are listed below.

Function Block Name	Symbol
Analog Input	AI
Analog Output	AO
Bias/Gain	BG
Control Selector	CS
Discrete Input	DI
Discrete Output	DO
Manual Loader	ML
Proportional/Derivative	PD
Proportional/Integral/Derivative	PID
Ratio	RA

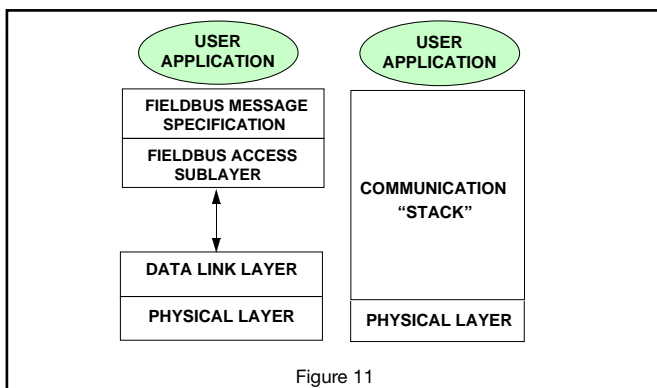

Figure 11

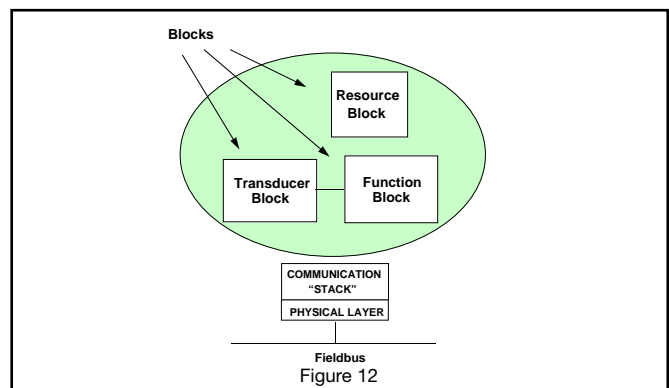

Figure 12

The following eleven standard function blocks are defined by the [FF-892 Function Block Application Process – Part 3](#).

Function Block Name	Symbol
Device Control	DC
Output Splitter	OS
Signal Characterizer	SC
Lead Lag	LL
Deadtime	DT
Integrator (Totalizer)	IT
Setpoint Ramp Generator	SPG
Input Selector	IS
Arithmetic	AR
Timer	TMR
Analog Alarm	AAL

The following four standard function blocks are defined by the [FF-893 Function Block Application Process – Part 4](#).

Function Block Name	Symbol
Multiple Analog Input	MAI
Multiple Analog Output	MAO
Multiple Discrete Input	MDI
Multiple Discrete Output	MDO

The Flexible Function Block is defined by the [FF-894 Function Block Application Process – Part 5](#). A flexible Function Block (FFB) is a user defined block. The FFB allows a manufacturer or user to define block parameters and algorithms to suit an application that interoperates with standard function blocks and host systems (Figure 13).

Function blocks can be built into fieldbus devices as needed to achieve the desired device functionality.

For example, a simple temperature transmitter may contain an AI function block. A control valve might contain a PID function block as well as the expected AO block. Thus, a complete control loop can be built using only a simple transmitter and a control valve (Figure 14).

3.1.3 Transducer Blocks

[FF-902 Transducer Block Application Process – Part 1](#)

[FF-903 Transducer Block Application Process – Part 2](#)

Like the Resource Block, the Transducer Blocks are used to configure devices.

Transducer Blocks decouple Function Blocks from the local input/output functions required to read sensors and command output hardware. They contain information such as calibration date and sensor type.

3.1.3.1 Supporting Objects

The following additional objects are defined in the User Application:

Link Objects define the links between Function Block inputs and outputs internal to the device and across the fieldbus network.

Trend Objects allow local trending of function block parameters for access by hosts or other devices.

Alert Objects allow reporting of alarms and events on the fieldbus.

Multi-Variable Container (MVC) Object serves to “encapsulate” multiple Function Block parameters in order to optimize communications for Publishing-Subscriber and Report Distribution transactions. It has a user-configured list to define the required parameters, whose data values are referenced in a variable list.

View Objects are predefined groupings of block parameter sets that can be displayed by the human/machine interface. The function block specification defines four views for each type of block. Figure 15 shows an example of how common Function Block variables map into the views. Only a partial listing of the block parameters is shown in the example.

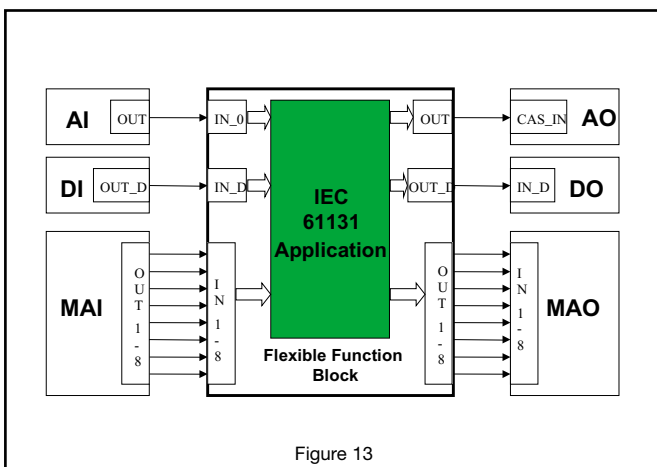
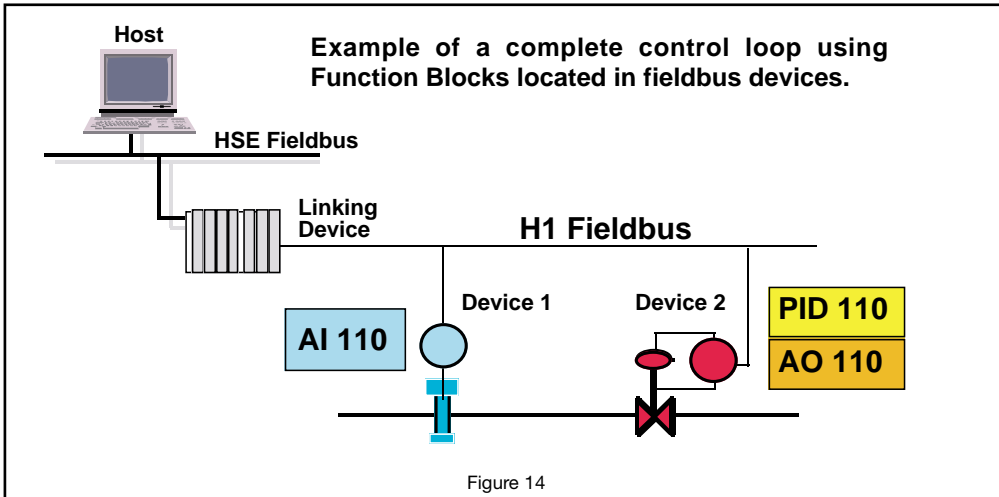
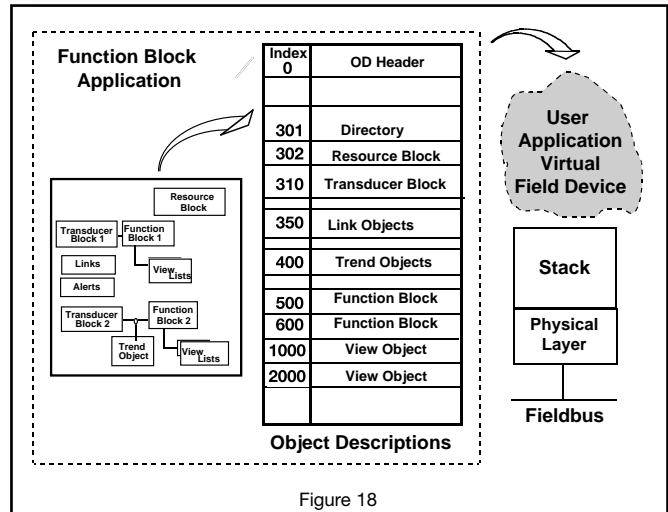
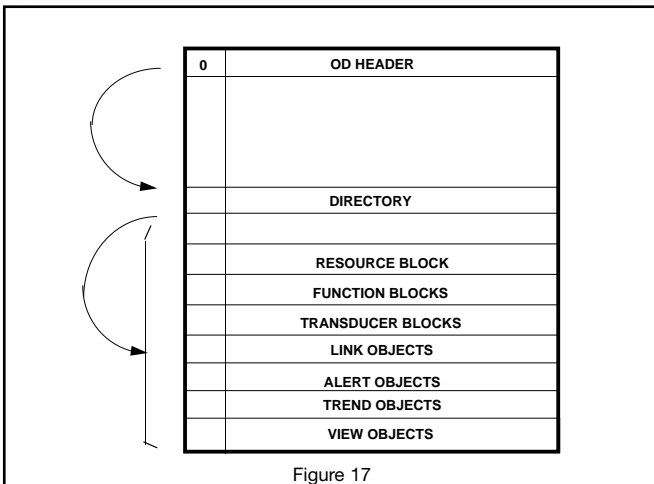
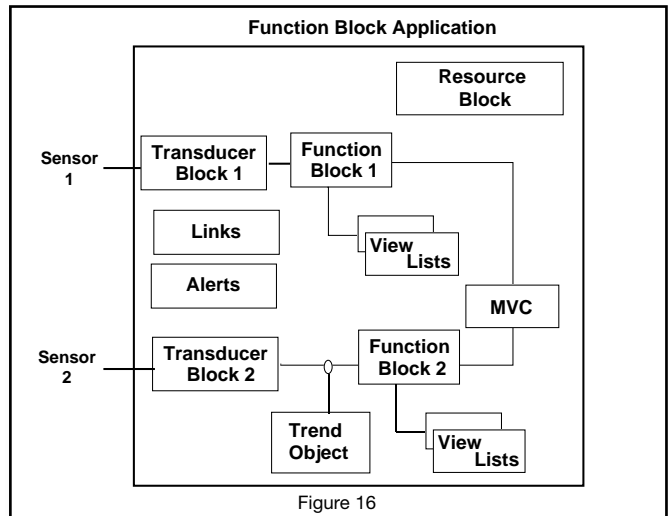
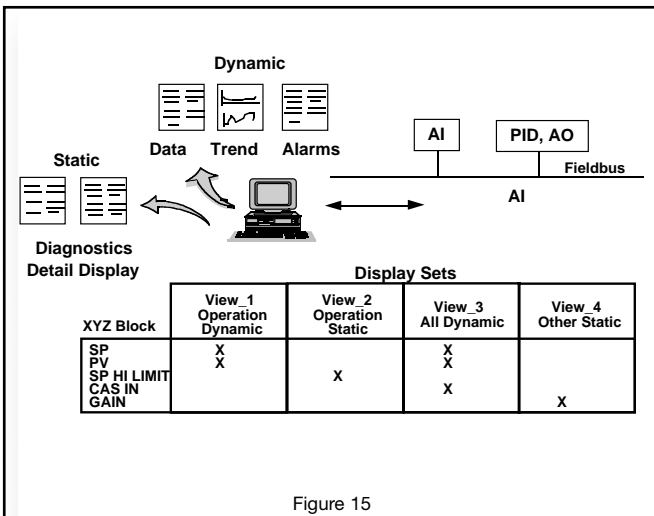

Figure 13



- VIEW_1 - Operation Dynamic - Information required by a plant operator to run the process.
- VIEW_2 - Operation Static - Information which may need to be read once and then displayed along with the dynamic data.
- VIEW_3 - All Dynamic - Information which is changing and may need to be referenced in a detailed display.
- VIEW_4 - Other Static - Configuration and maintenance information.



3.1.4 Fieldbus Device Definition

The fieldbus device definition is intended for remote I/O devices having many function blocks from which data shall be communicated

The function of a fieldbus device is determined by the arrangement and interconnection of blocks (Figure 16).

The device functions are made visible to the fieldbus communication system through the User Application Virtual Field Device (VFD) discussed in Section 3.4.3.1.

The header of the User Application object dictionary points to a Directory which is always the first entry in the function block application. The Directory provides the starting indexes of all of the other entries used in the Function Block application (Figure 17). The VFD object descriptions and their associated data are accessed remotely over the fieldbus network using Virtual Communication Relationships (VCRs).

TN-003 Profile and Profile Revision

Each block has a “Profile” (i.e. a code) that indicates the type of block (e.g. the standard PID block is code 0108 in hexadecimal). Based on this code a host can tell if a block is a standard block, an enhanced block or a manufacturer custom block. The engineering tool can now build a control strategy completely independent of the device you will eventually use. The process engineer can build the control strategy and then let the instrument engineers assign the blocks to devices later.

For example, in the basic PID control template the standard “0108” FF PID block is used. When the block is later assigned to a device the engineering tool confirms with the Capability File of the device that “0108” standard PID is supported. This means you can drag and drop the same block into a

transmitter, positioner or central controller without having to change to another block because all devices support the standard blocks. It also means that if you put in another device in the future that supports 0108, you can do so without having to change the block.

The graphical FOUNDATION function block diagram programming language is used to configure control strategies.

3.2 Function Block Scheduling

A schedule building tool is used to generate function block and Link Active Scheduler (LAS) schedules. As an example, assume that the schedule building tool has built the following schedules for the loop previously described in Figure 14.

The schedules contain the start time offset from the beginning of the “absolute link schedule start time.” The absolute link schedule start time is known by all devices on the fieldbus (Figure 19).

A “macrocycle” is a single iteration of a schedule within a device. The following figure shows the relationships between the absolute link schedule start time, LAS macrocycle, device macrocycles, and the start time offsets.

	Offset from Absolute Link Schedule Start Time
Scheduled AI Function Block Extension	0
Scheduled Communications of AI	20
Scheduled PID Function Block Execution	30
Scheduled AO Function Block Execution	50

Figure 19

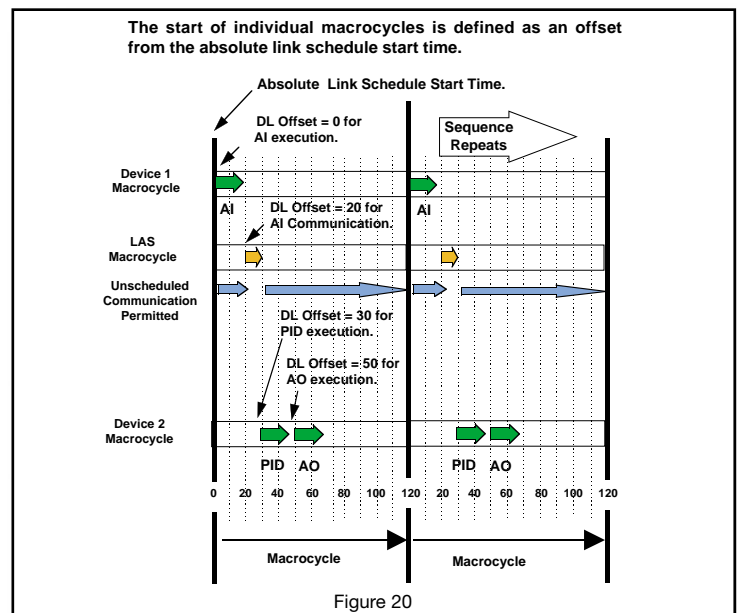

In Figure 20, System Management in the transmitter will cause the AI function block to execute at offset 0. At offset 20 the Link Active Scheduler (LAS) will issue a Compel Data (CD) to the AI function block buffer in the transmitter and data in the buffer will be published on the fieldbus.

At offset 30 System Management in the valve will cause the PID function block to execute followed by execution of the AO function block at offset 50. The pattern exactly repeats itself assuring the integrity of the control loop dynamics.

Note that during the function block execution, the LAS is sending the Pass Token message to all devices so that they can transmit their unscheduled messages such as alarm notifications or operator setpoint changes.

For this example, the only time that the fieldbus can not be used for unscheduled messages is from offset 20 to offset 30 when the AI function block data is being published on the fieldbus.

On the HSE fieldbus the function blocks execute as shown but, since there is no LAS, the communication is immediate instead of scheduled

3.2.1 Application Clock Distribution

FOUNDATION fieldbus supports an application clock distribution function. The application clock is usually set equal to the local time of day or to Universal Coordinated Time.

System Management has a time publisher which periodically sends an application clock synchronization message to all fieldbus devices. The data link scheduling time is sampled and sent with the application clock message so that the receiving devices can adjust their local application time. Between synchronization messages, application clock time is independently maintained in each device based on its own internal clock.

Application Clock synchronization allows the devices to time stamp data throughout the fieldbus network. If there are backup application clock publishers on the fieldbus, a backup publisher will become active if the currently active time publisher should fail.

3.2.2 Device Address Assignment

Every fieldbus device must have a unique network address and physical device tag for the fieldbus to operate properly.

To avoid the need for address switches on the instruments, assignment of network addresses can be performed by configuration tools using System Management services.

The sequence for assigning a network address to a new device is as follows:

- An unconfigured device will join the network at one of four special default addresses.
- A configuration tool will assign a physical device tag to the new device using System Management services.
- A configuration tool will choose an unused permanent address and assign this to the device using System Management services.
- The sequence is repeated for all devices that enter the network at a default address.
- Device store the physical device tag and node address in non-volatile memory, so the device will retain these settings after a power failure.

3.2.3 Find Tag Service

For the convenience of host systems and portable maintenance devices, System Management supports a service for finding devices or variables by a tag search.

The “find tag query” message is broadcast to all fieldbus devices. Upon receipt of the message, each device searches its Virtual Field Devices (VFD) for the requested tag and returns complete path information (if the tag is found) including the network address, VFD number, virtual communication relationship (VCR) index, and object dictionary (OD) index. Once the path is known, the host or maintenance device can access the data for the tag.



3.3 Device Descriptions

A device is supplied with three device support files: two Device Description Files and one Capability File. A critical characteristic required of fieldbus devices is interoperability. To achieve interoperability, Device Description (DD) technology is used in addition to standard function block parameter and behavior definitions. DDs are platform and operating system independent.

The DD provides an extended description of each object in the Virtual Field Device (VFD) as shown in Figure 21.

The DD provides information needed for a control system or host to understand the meaning of the data in the VFD including the human interface for functions such as calibration and diagnostics. Thus, the DD can be thought of as a “driver” for the device.

The DDs are similar to the drivers that your personal computer (PC) uses to operate different printers and other devices that are connected to the PC. Any control system or host can operate with the device if it has the device's DD.

3.3.1 Device Description Tokenizer

 [FD-900 Device Description Language Specification](#)

 [FD-100 DDL Tokenizer User's Manual](#)

The DD is written in a standardized programming language known as Device Description Language (DDL). A PC-based tool called the “Tokenizer” converts DD source input files into DD output files by replacing key words and standard strings in the source file with fixed “tokens”. The Fieldbus Foundation (FF) provides DDs for all standard Resource, Function and Transducer Blocks. Device suppliers build a DD by importing the Standard DDs. Suppliers may also add supplier specific features such as calibration and diagnostic procedures to their devices.

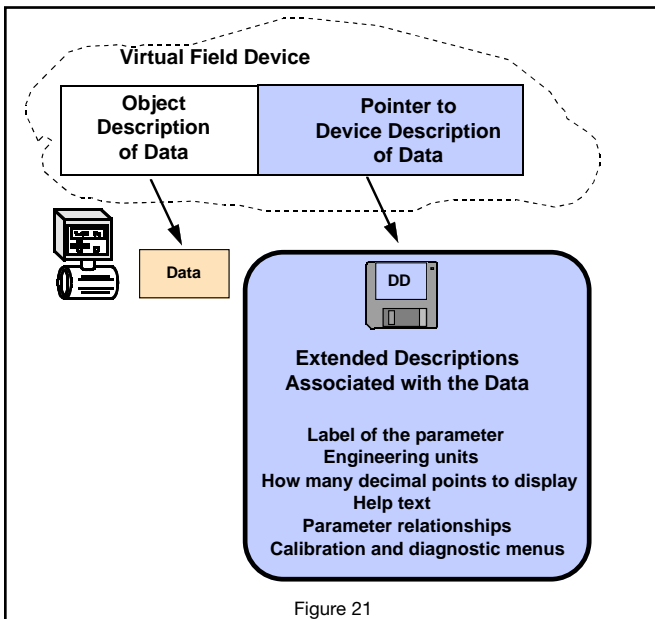

Figure 21

Device Descriptions for registered field devices can be found on the Fieldbus Foundation's website at <http://www.fieldbus.org>.

3.3.2 Device Description Services (DDS)

 **FD-110 DDS User's Guide**

On the host side, library functions called Device Description Services (DDS) are used to read the device descriptions (Figure 22).

Note that DDS reads descriptions, not operational values. The operational values are read from the fieldbus device over the fieldbus using FMS communication services.

New devices are added to the fieldbus by simply connecting the device to the fieldbus wire and providing the control system or host with the DD for the new device (Figure 23).

DDS technology allows operation of devices from different suppliers on the same fieldbus with only one version of the host human interface program.

3.3.3 Device Description Hierarchy

The Fieldbus Foundation has defined a hierarchy of Device Descriptions (DD) to make it easier to build devices and perform system configuration. The hierarchy is shown in Figure 24.

The first level in the hierarchy is referred to as Universal Parameters. Universal Parameters consist of common attributes such as Tag, Revision, Mode, etc. All blocks must include the Universal Parameters.

The next level in the hierarchy is Function Block Parameters. At this level, parameters are defined for the standard Function Blocks. Parameters for the standard Resource Block are also defined at this level.

The third level is called Transducer Block Parameters. At this level, parameters are defined for the standard Transducer Blocks. In some cases, the transducer block specification may add parameters to the standard Resource Block.

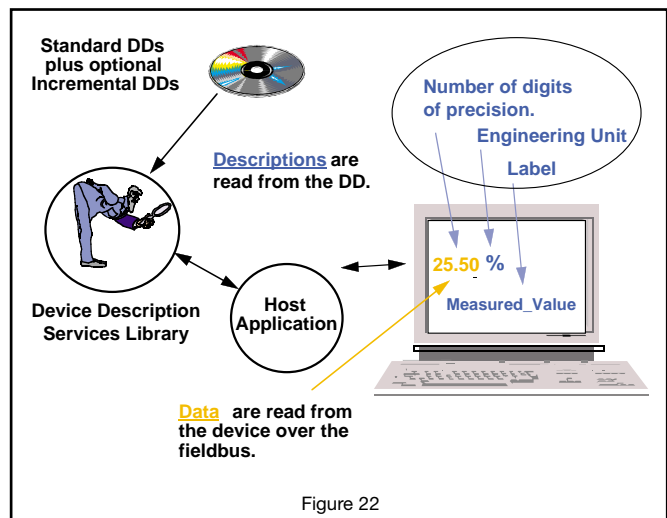

Figure 22

The Fieldbus Foundation has written the Device Descriptions for the first three layers of the hierarchy. These are the standard Fieldbus Foundation DDs.

The fourth level of the hierarchy is called Manufacturer Specific Parameters. At this level, each manufacturer is free to add additional parameters to the Function Block Parameters and Transducer Block Parameters.

3.3.4 Capability Files

 **FF-103 Common File Format**

The Capability File tells the host what resources the device has in terms of function blocks and VCRs etc. This allows the host to configure for the device even if not connected to it. The host can ensure that only functions supported by the device are allocated to it, and that other resources are not exceeded.

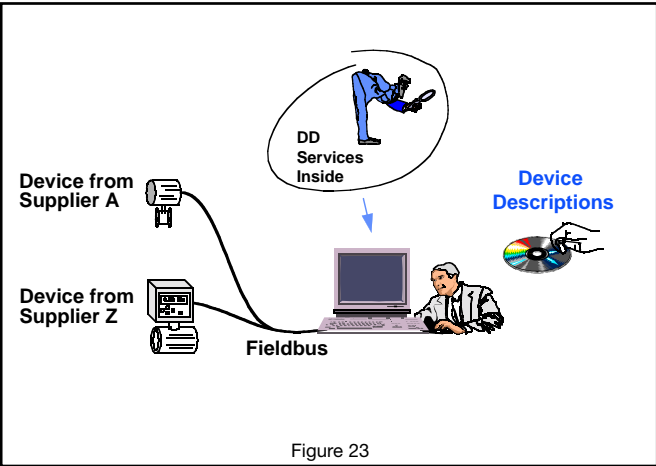

Figure 23

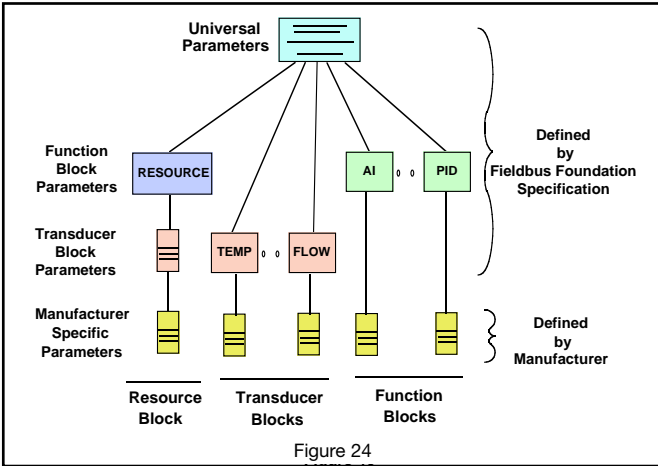

Figure 24

3.4 H1 Communication Stack

The following sections will describe the operation of the layers in the Communication Stack (Figure 25).

3.4.1 The Data Link Layer (DLL)

- 📖 FF-806 Data Link Protocol Specification Bridge Operation Addendum
- 📖 FF-821 Data Link Layer Services Subset Specification
- 📖 FF-822 Data Link Layer Protocol Subset Specification

IEC/TS 61158-3:1999 Digital data communications for measurement and control — Field bus for use in industrial control systems — Part 3: Data link service definition

IEC/TS 61158-4:1999 Digital data communications for measurement and control — Field bus for use in industrial control systems — Part 4: Data link protocol specification

Layer 2, the Data Link Layer (DLL), controls transmission of messages onto the fieldbus. The DLL manages access to the fieldbus through a deterministic centralized bus scheduler called the Link Active Scheduler (LAS).

The DLL is a subset of the approved IEC standard.

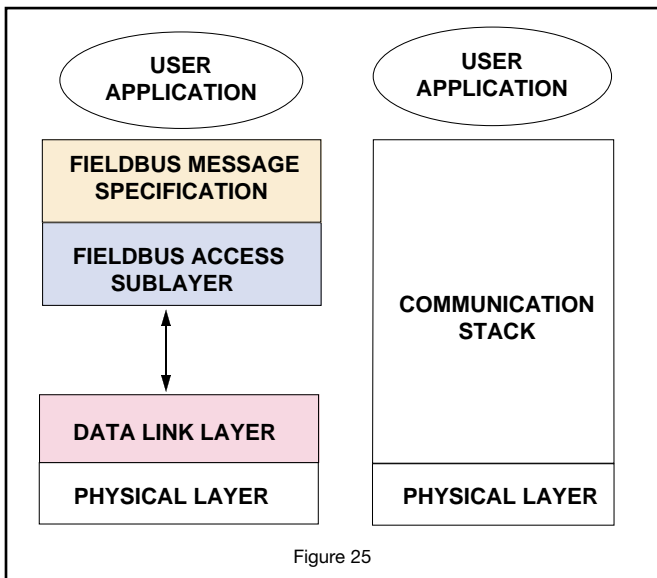

Figure 25

3.4.1.1 Device Types

Two types of devices are defined in the DLL specification:

- Basic Device
- Link Master

Link Master devices are capable of becoming the Link Active Scheduler (LAS). **Basic Devices** do not have the capability to become the LAS (Figure 26).

3.4.1.2 Scheduled Communication

The Link Active Scheduler (LAS) has a list of transmit times for all data buffers in all devices that need to be cyclically transmitted.

When it is time for a device to send a buffer, the LAS issues a Compel Data (CD) message to the device.

Upon receipt of the CD, the device broadcasts or “publishes” the data in the buffer to all devices on the fieldbus. Any device configured to receive the data is called a “subscriber” (Figure 27).

Scheduled data transfers are typically used for the regular, cyclic transfer of control loop data between devices on the fieldbus.

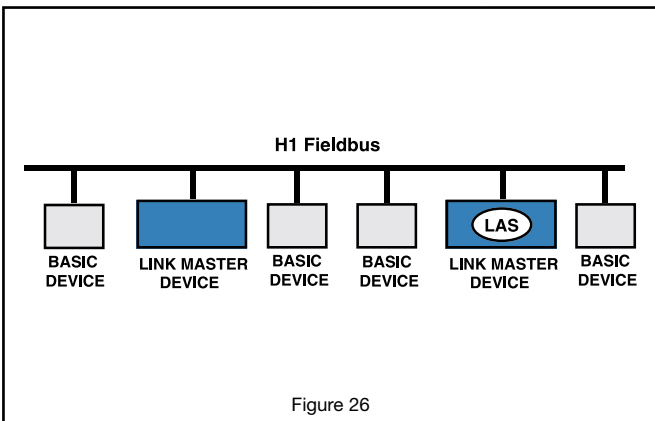

Figure 26

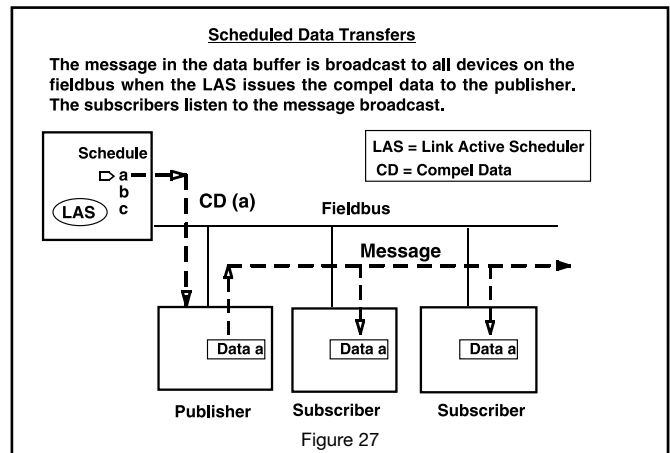

Figure 27

3.4.1.3 Unscheduled Communication

All of the devices on the fieldbus are given a chance to send “unscheduled” messages between transmissions of scheduled messages.

The LAS grants permission to a device to use the fieldbus by issuing a pass token (PT) message to the device. When the device receives the PT, it is allowed to send messages until it has finished or until the “delegated token hold time” has expired, whichever is the shorter time (Figure 28).

3.4.1.4 Link Active Scheduler Operation

The following sections describe the overall operation of the Link Active Scheduler (LAS). The algorithm used by the LAS is shown in Figure 29.

3.4.1.4.1 CD Schedule

The CD Schedule contains a list of activities that are scheduled to occur on a cyclic basis. At precisely the scheduled time, the LAS sends a Compel Data (CD) message to a specific data buffer in a fieldbus device. The device immediately broadcasts or “publishes” a message to all devices on the fieldbus. This is the highest priority activity performed by the LAS. The remaining operations are performed between scheduled transfers.

3.4.1.4.2 Live List Maintenance

The list of all devices that are properly responding to the Pass Token (PT) is called the “Live List.”

New devices may be added to the fieldbus at any time. The LAS periodically sends Probe Node (PN) messages to the addresses not in the Live List. If a device is present at the address and receives the PN, it immediately returns a Probe Response (PR) message. If the device answers with a PR, the LAS adds the device to the Live List and confirms its addition by sending the device a Node Activation message.

The LAS is required to probe at least one address after it has completed a cycle of sending PTs to all devices in the Live List.

The device will remain in the Live List as long as it responds properly to the PTs sent from the LAS. The LAS will remove a device from the Live List if the device does not either use the token or immediately return it to the LAS after three successive tries.

Whenever a device is added or removed from the Live List, the LAS broadcasts changes to the Live List to all devices. This allows each Link Master device to maintain a current copy of the Live List.

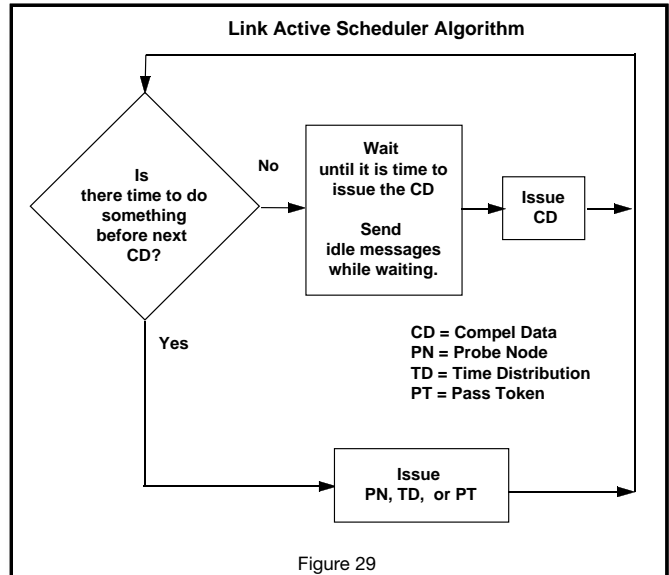
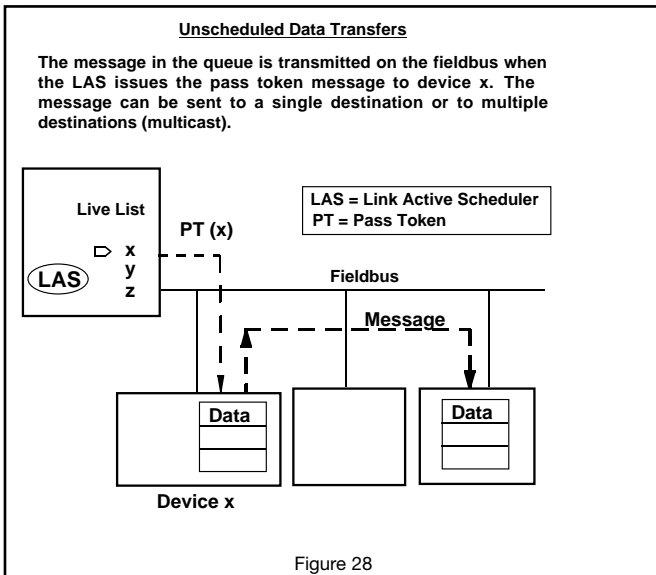

3.4.1.4.3 Data Link Time Synchronization

The LAS periodically broadcasts a Time Distribution (TD) message on the fieldbus so that all devices have exactly the same data link time. This is important because scheduled communications on the fieldbus and scheduled function block executions in the User Application are based on information obtained from these messages.

3.4.1.4.4 Token Passing

The LAS sends a Pass Token (PT) message to all devices in the Live List. The device is allowed to transmit unscheduled messages when it receives the PT.

3.4.1.4.5 LAS Redundancy

A fieldbus may have multiple Link Masters. If the current LAS fails, one of the Link Masters will become the LAS and the operation of the fieldbus will continue. The fieldbus is designed to “fail operational.”

3.4.2 System Management

FF-800 System Management Specification

Function Blocks must execute at precisely defined intervals and in the proper sequence for correct control system operation.

System management synchronizes execution of the Function Blocks to a common time clock shared by all devices.

System management also handles other important system features such as publication of the time of day to all devices, including automatic switchover to a redundant time publisher and searching for parameter names or “tags” on the fieldbus. Fieldbus devices do not use jumpers or switches to configure addresses. Instead, device addresses are set by configuration tools using System Management services.

All of the configuration information needed by System Management such as the Function Block schedule is described by object descriptions in the Network and System Management Virtual Field Device (VFD). This VFD provides access to the System Management Information Base (SMIB), and also to the Network Management Information Base (NMIB).

3.4.3 Fieldbus Access Sublayer (FAS)

FF-875 Fieldbus Access Sublayer Specification

The FAS uses the scheduled and unscheduled features of the Data Link Layer to provide a service for the Fieldbus Message Specification (FMS). The types of FAS services are described by Virtual Communication Relationships (VCR).

The VCR is like the speed dial feature on your memory telephone. There are many digits to dial for an international call such as international access code, country code, city code, exchange code and, finally, the specific telephone number.

This information only needs to be entered once and then a “speed dial number” is assigned.

After setup, only the speed dial number needs to be entered for the dialing to occur. Likewise, after configuration, only the VCR number is needed to communicate with another fieldbus device.

Just as there are different types of telephone calls such as person to person, collect, or conference calls, there are different types of VCRs.

3.4.3.1 Client/Server VCR Type

The Client/Server VCR Type is used for queued, unscheduled, user initiated, one to one, communication between devices on the fieldbus.

Queued means that messages are sent and received in the order submitted for transmission, according to their priority, without overwriting previous messages.

When a device receives a Pass Token (PT) from the LAS, it may send a request message to another device on the fieldbus. The requester is called the “Client” and the device that received the request is called the “Server.” The Server sends the response when it receives a PT from the LAS.

The Client/Server VCR Type is used for operator initiated requests such as setpoint changes, tuning parameter access and change, alarm acknowledge, and device upload and download.

3.4.3.2 Report Distribution VCR Type

The Report Distribution VCR Type is used for queued, unscheduled, user initiated, and one-to-many communications.

When a device with an event or a trend report receives a PT from the LAS, it sends its message to a “group address” defined for its VCR. Devices that are configured to listen for that VCR will receive the report.

The Report Distribution VCR Type is typically used by fieldbus devices to send alarm notifications to the operator consoles.

3.4.3.3 Publisher/Subscriber VCR Type

The Publisher/Subscriber VCR Type is used for buffered, one-to-many communications.

Buffered means that only the latest version of the data is maintained within the network. New data completely overwrites previous data.

When a device receives the Compel Data (CD), the device will “Publish” or broadcast its message to all devices on the fieldbus. Devices that wish to receive the Published message are called “Subscribers.”

The CD may be scheduled in the LAS, or it may be sent by Subscribers on an unscheduled basis. An attribute of the VCR indicates which method is used.

The Publisher/Subscriber VCR Type is used by the field devices for cyclic, scheduled, publishing of User Application function block input and outputs such as Process Variable (PV) and Primary Output (OUT) on the fieldbus.

3.4.3.4 Summary of VCR Types

(Figure 30)

3.4.4 Fieldbus Message Specification (FMS)

 [FF-870 Fieldbus Message Specification](#)

Fieldbus Message Specification (FMS) services allow user applications to send messages to each other across the fieldbus using a standard set of message formats. FMS describes the communication services, message formats, and protocol behavior needed to build messages for the User Application (Figure 31).

Data that is communicated over the fieldbus is described by an “object description.” Object descriptions are collected together in a structure called an “Object Dictionary” (OD), (Figure 32).

FIELDBUS ACCESS SUBLAYER SERVICES		
Client/Server VCR Type	Report Distribution VCR Type	Publisher/Subscriber VCR Type
Used for Operator Messages	Used for Event Notification and Trend Reports	Used for Publishing Data
Setpoint changes Mode changes Tuning changes Upload/Download Alarm Management Access display views Remote diagnostics	Send process alarms to operator consoles. Send trend reports to data historians.	Send transmitter PV to PID control block and operator console.
DATA LINK LAYER SERVICES		

Figure 30

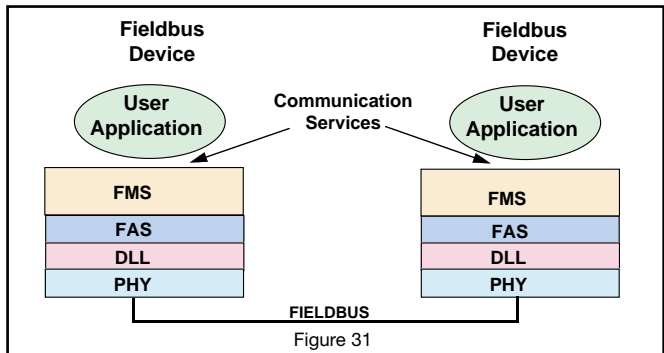

Figure 31

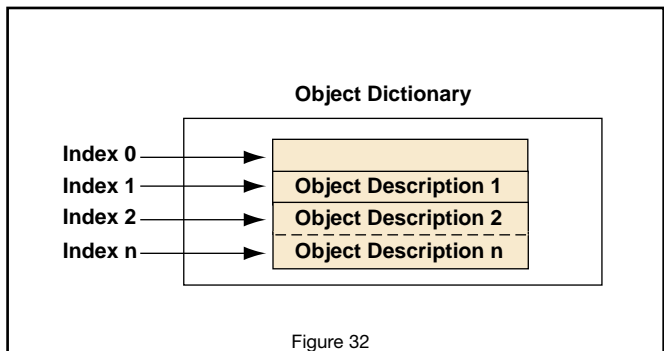

Figure 32

The object description is identified by its “index” in the OD. Index 0, called the object dictionary header, provides a description of the dictionary itself, and defines the first index for the object descriptions of the User Application. The User Application object descriptions can start at any index above 255.

Index 255 and below define standard data types such as boolean, integer, float, bitstring, and data structures that are used to build all other object descriptions.

3.4.4.1 Virtual Field Device (VFD)

A “Virtual Field Device” (VFD) is used to remotely view local device data described in the object dictionary. A typical device will have at least two VFDs (Figure 33).

Network Management (see [FF-801 Network Management Specification](#)) is part of the Network and System Management Application. It provides for the configuration of the communication stack. The Virtual Field Device (VFD) used for Network Management is also used for System Management. This VFD provides access to the Network Management Information Base (NMIB) and to the System Management Information Base (SMIB). NMIB data includes Virtual Communication Relationships (VCR), dynamic variables, statistics, and Link Active Scheduler (LAS) schedules (if the device is a Link Master). SMIB data includes device tag and address information, and schedules for function block execution.

3.4.4.2 FMS Services

Detailed descriptions for each service are provided in the [FF-870 Fieldbus Message Specification](#).

3.4.4.2.1 Context Management Services

The following FMS services are used to establish and release Virtual Communications Relationships (VCR) with, and determine the status of a VFD.

<i>Initiate</i>	Establish communications
<i>Abort</i>	Release communications
<i>Reject</i>	Reject improper service
<i>Status</i>	Read a device status
<i>UnsolicitedStatus</i>	Send unsolicited status
<i>Identify</i>	Read vendor, type and version

3.4.4.2.2 Object Dictionary Services

The following FMS services allow the User Application to access and change the Object Descriptions (OD) in a VFD.

<i>GetOD</i>	Read an object dictionary(OD)
<i>InitiatePutOD</i>	Start an OD Load
<i>PutOD</i>	Load an OD into a device
<i>TerminatePutOD</i>	Stop an OD Load

3.4.4.2.3 Variable Access Services

The following FMS services allow the user application to access and change variables associated with an object description.

<i>Read</i>	Read a variable
<i>Write</i>	Write a variable
<i>InformationReport</i>	Send Data*
<i>DefineVariableList</i>	Define a Variable List
<i>DeleteVariableList</i>	Delete a Variable List

*Can use **Publisher/Subscriber** or **Report Distribution VCR** Types.

3.4.4.2.4 Event Services

The following FMS services allow the user application to report events and manage event processing.

<i>EventNotification</i>	Report an event*
<i>AcknowledgeEventNotification</i>	Acknowledge an event
<i>AlterEventConditionMonitoring</i>	Disable / Enable event

* Can use **Report Distribution VCR** Type

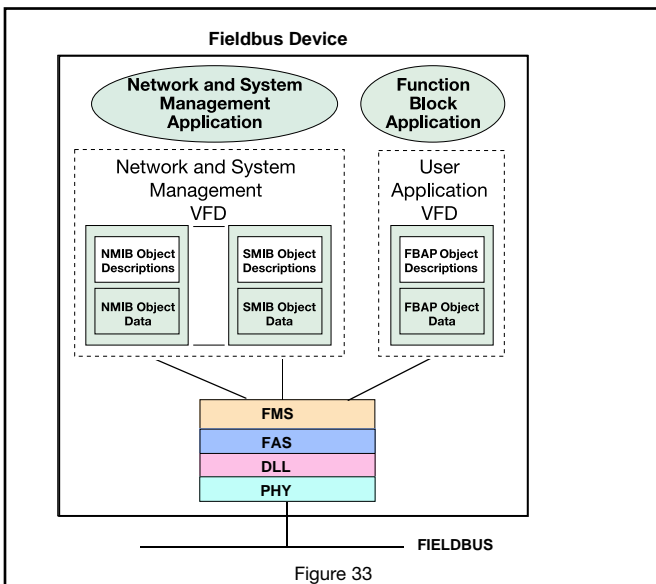

Figure 33

3.4.4.2.5 Upload/Download Services

It is often necessary to remotely upload or download data and programs over the fieldbus, especially for more complex devices such as programmable logic controllers.

To allow uploads and downloads using the FMS services, a "Domain" is used. A Domain represents a memory space in a device.

The following FMS services allow the User Application to upload and download a Domain in a remote device.

<i>RequestDomainUpload</i>	Request Upload
<i>InitiateUploadSequence</i>	Open Upload
<i>UploadSegment</i>	Read Data from Device
<i>TerminateUploadSequence</i>	Stop Upload
<i>RequestDomainDownload</i>	Request Download
<i>InitiateDownloadSequence</i>	Open Download
<i>DownloadSegment</i>	Send Data to Device
<i>TerminateDownloadSequence</i>	Stop Download
<i>GenericInitiateDownloadSequence</i>	Open Download
<i>GenericDownloadSegment</i>	Send Data to Device
<i>GenericTerminateDownloadSequence</i>	Stop Download

3.4.4.2.6 Program Invocation Services

The "Program Invocation" (PI) allows the execution of a program in one device to be controlled remotely.

A device could download a program into a Domain (see previous section) of another device using the download service and then remotely operate the program by issuing PI service requests. The state diagram for the PI is shown as an example of FMS protocol behavior later in this document.

<i>CreateProgramInvocation</i>	Create a program object
<i>DeleteProgramInvocation</i>	Delete a program object
<i>Start</i>	Start a program
<i>Stop</i>	Stop a program
<i>Resume</i>	Resume program execution
<i>Reset</i>	Reset the program
<i>Kill</i>	Remove the program

3.4.4.3 Message Formatting

 [ASN.1 Tutorial and Reference – Steedman](#)

The exact formatting of FMS messages is defined by a formal syntax description language called Abstract Syntax Notation 1 (ASN.1).

ASN.1 was developed by the International Telegraph and Telephone Consultative Committee (CCITT) in the early 1980s as a part of the CCITT mail standardization activities.

See Figure 34 for a partial example of ASN.1 definition for the FMS Read service.

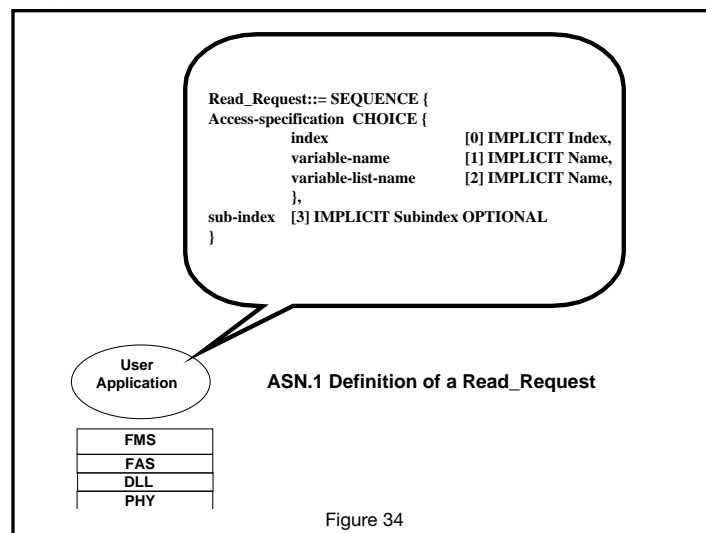

Figure 34

Fieldbus signals are encoded using the well-known Manchester Biphasic-L technique. The signal is called “synchronous serial” because the clock information is embedded in the serial data stream.

Data is combined with the clock signal to create the fieldbus signal as shown in the figure below. The receiver of the fieldbus signal interprets a positive transition in the middle of a bit time as a logical “0” and a negative transition as a logical “1” (Figure 12).

Special characters are defined for the preamble, start delimiter, and end delimiter (Figure 38).

The preamble is used by the receiver to synchronize its internal clock with the incoming fieldbus signal. Special N+ and N- codes are in the start delimiter

and end delimiter. Note that the N+ and N- signals do not transition in the middle of a bit time. The receiver uses the start delimiter to find the beginning of a fieldbus message. After it finds the start delimiter, the receiver accepts data until the end delimiter is received.

3.5.1 31.25 kbit/s Fieldbus Signaling

The transmitting device delivers ± 10 mA at 31.25 kbit/s into a 50 ohm equivalent load to create a 1.0 volt peak-to-peak voltage modulated on top of the direct current (DC) supply voltage.

The DC supply voltage can range from 9 to 32 volts. However, for Intrinsically Safe (I.S.) applications, the allowed power supply voltage depends on the barrier rating (Figure 39).

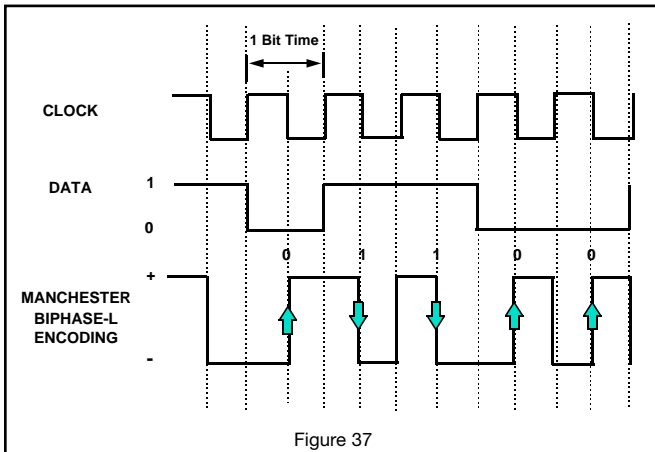

Figure 37

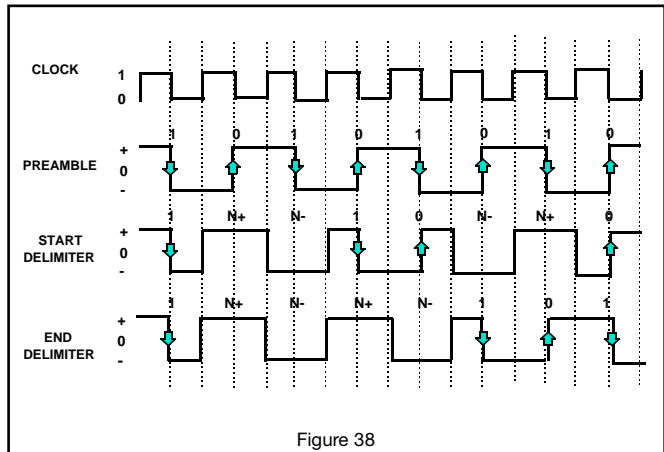

Figure 38

31.25 kbit/s devices can be powered directly from the fieldbus and can operate on wiring previously used for 4-20 mA devices.

The 31.25 kbit/s fieldbus also supports I.S. fieldbuses with bus powered devices. To accomplish this, an I.S. barrier is placed between the power supply in the safe area and the I.S. device in the hazardous area.

To address Intrinsic Safety applications, the Fieldbus Foundation supports using either the traditional Entity model or the newer Fieldbus Intrinsically Safe Concept (FISCO). The mixing of the Entity model with the FISCO approach in the preparation of a system design is not recommended.

3.5.2 31.25 kbit/s Fieldbus Wiring

- [AG-140 31.25 kbit/s Wiring and Installation Guide](#)
- [AG-163 31.25 kbit/s Intrinsically Safe Systems Application Guide](#)
- [AG-165 Fieldbus Installation and Planning Guide](#)

The 31.25 kbit/s fieldbus allows stubs or “spurs” (Figure 40).

The length of the fieldbus is determined by the communication rate, cable type, wire size, bus power option, and I.S. option.

Figure 41 gives a summary of examples of options available in the Physical Layer standard.

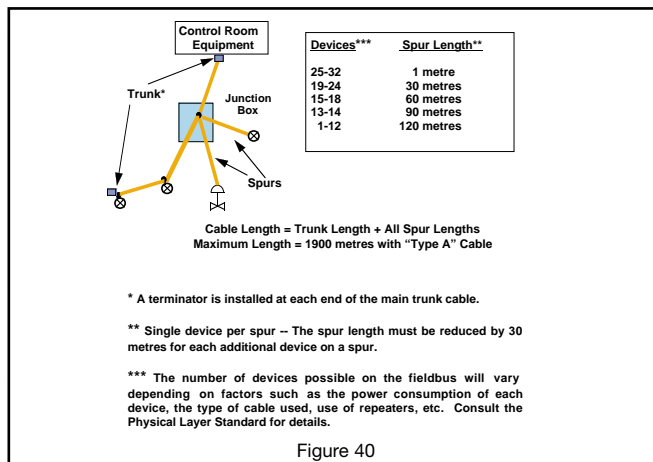
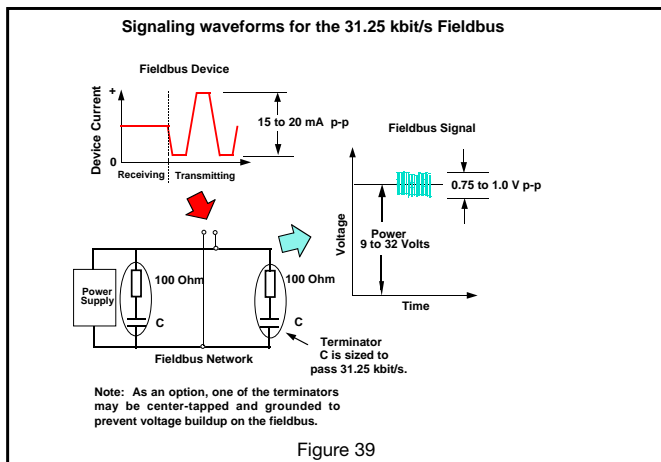

Characteristics	Data Rate		
Type	31.25 kbit/s	31.25 kbit/s	31.25 kbit/s
Voltage	Voltage	Voltage	Voltage
Topology	Bus/tree	Bus/tree	Bus/tree
Bus Power	none	DC	DC
Classification	Intrinsically Safe		
Number of Devices*	2-32	2-6	2-12
Cable Length	1900 m	1900 m	1900 m
Spur Length	120 m	120 m	120 m

Figure 41

* The number of devices possible on a fieldbus link depends on factors such as the power consumption of each device, the type of cable used, use of repeaters, etc. Consult the Physical Layer Standard for details. The number of network addresses available for each link is 240.



3.6 HSE Communication Stack

- [FF-581 System Architecture](#)
- [FF-586 Ethernet Presence](#)
- [FF-588 Field Device Access \(FDA\) Agent](#)
- [FF-589 HSE System Management](#)
- [FF-803 HSE Network Management](#)

Most Ethernet-based protocols are not fully open because part of the “stack” is proprietary. The lack of higher-level standards has prevented easy integration of other subsystems of the plant. The HSE standard includes the application and user layers, thereby making it a completely open protocol.

3.6.1 HSE Device Types

There are four basic HSE device categories, but many are typically combined into a single device: linking device, Ethernet device, host device, and gateway device. A Linking Device (LD) connects H1 networks to the HSE network. An Ethernet Device (ED) may execute function blocks and may have some conventional I/O. A Gateway Device (GD) interfaces other network protocols such as Modbus, DeviceNet or Profibus. A Host Device (HD) is an operator workstation or an OPC server.

H1 and HSE Benefits	
H1	HSE
List of Required Internet Protocols — TABLE A Internet RFC	
768	User Datagram Protocol (UDP)
791	Internet Protocol (IP)
792	Internet Control Message Protocol (ICMP)
793	Transmission Control Protocol (TCP) Optional
826	Ethernet Address Resolution Protocol (ARP)
1112	Internet Group Management Protocol (IGMP)
1122	Requirements for Internet Hosts — Communication Layers
1155	Structure and Identification of Management Information
1157	Simple Network Management Protocol (SNMP)
1213	Management Information Base-II
1533	DHCP Options and BOOTP Vendor Extensions
1541	Dynamic Host Configuration Protocol
1643	Definitions of Managed Objects for the Ethernet-like Interface Types
2030	Simple Network Time Protocol

3.6.1.1 HSE Device

HSE devices are Foundation fieldbus devices that contain an FDA Agent, an HSE System Management Kernel (SMK), and an HSE Network Management Agent (NMA) Virtual Field Device (VFD).

The HSE field device is an HSE device that is the HSE counterpart to the H1 field device. Instead of an H1 communications stack, it has an HSE communications stack.

3.6.1.2 Linking Device

The linking device is an HSE device that connects the HSE to one or more H1 links. It provides gateway services that map FDA SM and FMS messages to their H1 counterparts.

3.6.1.3. Gateway Device

- [FF-893 Function Block Application Process - Part 4](#)

The I/O gateway is an HSE device that is similar to the linking device, but it connects the HSE to one or more I/O devices or buses.

The MIO blocks are ideal to gateway remote-I/O protocols such as Modbus and Profibus-DP that contain mainly process input and output information into the fieldbus environment.

3.6.1.4. Host Device (OPC DA server)

Non-HSE devices capable of communicating with HSE devices. Examples include configurators and operator workstations.

3.6.2. Ethernet Presence

The HSE Presence in a HSE device provides services for Ethernet Stack initialization, general-purpose communication over the Ethernet media, time synchronization, and HSE Presence management. The HSE Presence is an addition to the Fieldbus Foundation H1 system and network management model. The HSE Presence does not replace this model, but rather adds services for HSE Presence management.

This specification is intended to encompass all the physical media and signaling rates described in IEEE Std 802.3 and IEEE Std 802.3u. Management



of the HSE Presence is employing SNMP augmented to support Fieldbus Foundation unique Ethernet Stack parameters.

The universal set of protocols which may be included in a given implementation of HSE Presence is identified in Table A.

3.6.3 Field Device Access (FDA)

The FDA Agent has the following objectives:

- Convey System Management (SM) services over UDP and Fieldbus Message Specification (FMS) services over UDP/TCP. This allows HSE and H1 field devices, conventional I/O devices, and non-FF I/O devices to be connected to the HSE through a linking or a gateway device.
- Republish H1 data from linking devices that do not support H1 bridging. This allows linking devices to be constructed from multiple standalone H1 interfaces instead of using an H1 bridge.
- Send and receive LAN redundancy messages to support redundancy of HSE interfaces in devices.

The FDA Agent allows control systems to operate over the HSE and/or through Linking Devices and it enables remote applications to access field devices of any type across UDP/TCP using a common interface.

3.6.4 HSE System Management

System management is the activity that integrates devices on an HSE network into a coherent communication system.

The following functions are supported:

- Each device has a unique, permanent identity and a system-specific configured name.
- Devices maintain version control information.
- Devices respond to requests to locate objects, including the device itself.
- Time is distributed to all devices on the network.
- Function block schedules are used to start function blocks.
- Devices are added and removed from the network without affecting other devices on the network.

3.6.5 HSE Network Management

HSE Network Management permits HSE host systems to conduct management operations over the HSE network with their associated devices with an HSE interface.

The following capabilities are provided by network management:

- Configuring the H1 Bridge, which performs data forwarding and republishing between H1 interfaces
- Loading the HSE Session List or single entries in this list. An HSE Session Endpoint represents a logical communication channel between two or more HSE devices.
- Loading the HSE VCR List or single entries in this list. An HSE VCR is a communication relationship used for accessing VFDs across the HSE.
- Performance Monitoring through the collection of statistics for Session Endpoints, HSE VCRs, and the H1 Bridge.
- Fault Detection Monitoring.

3.7 Redundancy

FF-593 High Speed Ethernet Redundancy

For use in factory and process automation, Ethernet has to be made industrial strength. FOUNDATION fieldbus HSE is based on Ethernet and is used at the host-level of the control system. The host-level network ties the whole system together linking the various subsystems to the host. Thus, the visibility of hundreds and perhaps thousands of loops depends on the host-level network as does any intra-area control loops. A complete failure could result in heavy losses. High availability for the host-level network is therefore paramount. HSE is the only open, Ethernet-based protocol to address the need for round-the-clock availability of network and devices. Because device and port redundancy requires interoperability beyond Ethernet and IP, other Ethernet solutions do not support it. HSE is the first standard protocol to offer functionality to select which device in a redundant pair and which one of redundant ports that a transmitting device should address. Exchange of redundancy management information is part of the standard protocol.

HSE is built on standard Ethernet, originally a technology for the office environment. However, industrial grade hardware is available and HSE has a number of functions built in to insure fault tolerance. The modern form of Ethernet uses UTP (Unshielded Twisted Pair) wiring using a hub-based star topology in which there is only one device per wire segment.



Therefore, devices can be disconnected and connected without disrupting other devices and any wire fault only affects a single device (i.e., the impact of a fault is reduced somewhat).

A shared hub is a multiple port repeater that joins several segments into a single network. A switched hub is a multiple port bridge that joins several networks together. Fiber optic media can be employed to increase tolerance towards electrical noise and ground potential differences further increasing the robustness of the system. Industrial grade hubs with redundant power supplies, wide temperature ranges, rugged enclosures, etc., are available for use in a tough plant environment.

3.7.1 Need for Host-Level Redundancy

The shutdown of a plant is extremely disruptive and downtime means heavy losses. At the host-level the network and devices are shared between many loops, making these parts very critical to the operation of the plant. If the host-level network is not functioning the operators would be unable to monitor and supervise the plant and, therefore, many loops would have to be shut down. The host-level network is also used for intra-area control loops that would have to be shut down. Unlike the field-level where high availability is achieved by distributing functionality thereby isolating faults to a small sector, at the rather centralized host-level redundancy is instead used to achieve high availability. Any Ethernet network can use media redundancy to achieve some measure of increased availability, but HSE also supports complete device and networking redundancy.

3.7.2 Media Redundancy

Any Ethernet device even with just a single port can have simple media redundancy using some form of port “splitter”. Splitters are implemented in different ways but all work in the same basic fashion. A single port is split in two, connecting devices together in a circle providing alternate communication paths. If communication in one direction is not possible, communication is routed the other way (i.e., the network is “self-healing”). The switchover time is very short. Recovery time is much faster than the traditional spanning tree algorithm, and thus operations will continue without any loss of data. A splitter may either be a transceiver handling a single port requiring one at every node, or may be implemented between hubs in a ring topology.

Media redundancy works only on the physical layer and is therefore independent of protocol used.

Some solutions require a central redundancy management device that may be an Achilles heel, whereas other solutions have the redundancy management built into the hubs. Very often the media redundancy ring is implemented using fiber optics. The ring is not a standard Ethernet topology and the special splitting hubs and transceivers usually use standard media but employ proprietary mechanisms to manage the switchover. Therefore, all the splitters in the ring have to come from the same manufacturer.

Simple media redundancy may be sufficient for some applications, but not all. For example, some applications combine media redundancy with fully duplicated networks and linking devices.

3.7.3 Complete Network Redundancy

The HSE protocol goes further than simple media redundancy. Special integrity-checking diagnostics and redundancy management part of the HSE protocol in each device enables use of two completely independent networks, redundant communication ports, and also redundant device pairs. All redundant Ethernet device pairs and the workstations are connected to both Ethernet buses. When a single unit has two ports these are named “A” and “B”. The switchover is totally bumpless and transparent. The redundancy scheme leaves several device options open (Figure 45), but they are all compatible with each other, e.g.:

- Redundant device pair where primary and secondary have one port each
- Redundant device pair where primary and secondary have two ports each
- Single device that has two ports

All parts of the network have redundancy, including the hubs (i.e. two independent networks ensuring that communication can continue even if one network fails). This means that the network can sustain multiple faults but still continue to function. Thus the networking is extremely reliable, minimizing loss of data and unnecessary shutdowns.

The philosophy of the HSE redundancy is one of “operational transparency and diagnostic visibility”.

This means that the control application sees either the primary or the secondary Ethernet device depending on which one is active, whereas the system diagnostics sees both. Thus, the diagnostics insures that even the inactive devices are fully functional and ready to take over at any moment. A wide diagnostic coverage is an integral part of the HSE protocol going far beyond mere hardware duplication. Every HSE device, including the host or any “redundancy manager”, independently keeps track of the status of the networks and all the devices on it. Because HSE is not only Ethernet media but also has a standard application layer, devices from different manufacturers periodically exchange their view of the network with each other using diagnostic messages through all ports on both networks which also serve as sign of life indication. Every device has a complete picture of the network to intelligently select which network, device and port to communicate with. Failure detection includes late and lost messages and duplication. Through exhaustive network diagnostics every device knows the health of the primary and secondary, as well as communication port A and B, of every other device on the network. Diagnostics in each device detect failure, allowing the device to respond to and circumvent these faults as well as notifying the operator. No other standard protocol has this level of redundancy capability. Because the redundancy management is distributed to each device, no centralized “redundancy manager” is required. In this way, the Achilles heel of centralized architectures are again avoided.

Every communication port has a unique IP address. The IP address does not change when the primary switches over to the secondary. Depending on the health of the network segments, communication ports and device pairs, the redundancy management in each device will pick the most suitable route to communicate with another device using the appropriate IP address. Therefore, the system can sustain multiple faults and still continue to operate.

The network, device and port redundancy work independently of the physical media. As such, it is possible to use a ring-topology media redundancy at the same time.

3.7.4 Device Redundancy

True device redundancy is implemented using two

identical devices, one primary and one secondary. The HSE protocol specifies how these devices communicate with others and how the communication is switched over. However, HSE does not specify how the functionality is switched or how device configuration and data are synchronized.

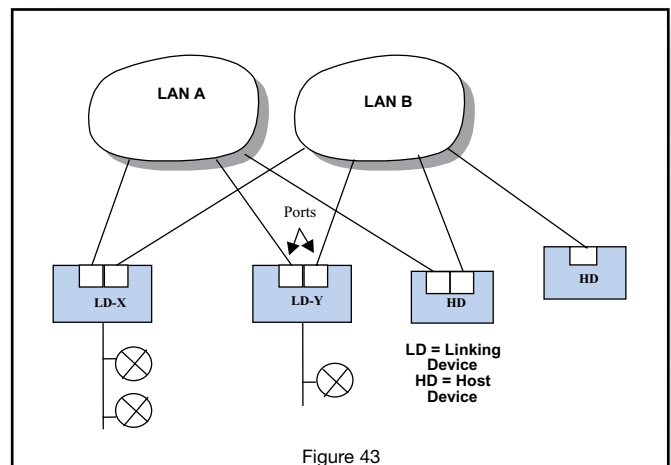
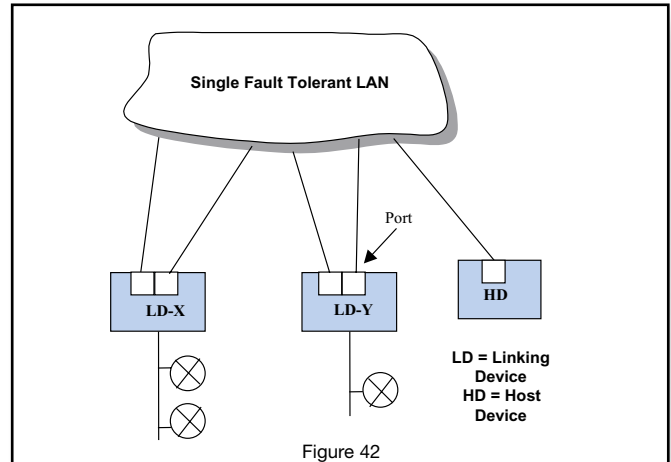

For example, a primary and secondary linking device are connected to the same H1 field-level network and the two redundant host-level networks providing two interfaces and two completely separate communication paths from the H1 fieldbus to the host. In case of any fault along the primary path, data can still pass through on the secondary path. This ensures that the plant floor data reaches the

operator even if one interface fails. FOUNDATION fieldbus always insures there is a window to the process. This compares favorably to a solution with only a single field-level interface.

Primary and secondary devices need to have identical configuration in order to allow for a quick switchover in case of failure. When a primary device fails the secondary takes over the role of the primary. Primary to secondary configuration data synchronization is typically done over the Ethernet. The HSE technology allows the primary and secondary units in the device pair to be physically separated i.e. mounted some distance apart. To eliminate the chance of common failures such as faulty backplane or faults due to exposure to stress.

3.7.5 LAN Topologies

This specification does not dictate the topology of HSE networks, but does divide them into three categories from a device perspective.

1. Single interface devices on a single LAN.
2. Dual interface devices on dual LANs.
3. Dual interface devices on a single LAN.

The distinction between the single LAN and dual LAN topologies is that a device with dual interfaces has the capability to receive its own transmissions on a single LAN topology, whereas this is not possible in the dual LAN topology.

Figure 44 illustrates the single interface devices on a single LAN. There is no redundancy as illustrated. While such systems do not benefit from using LAN redundancy, the devices are configured to send diagnostic messages to allow detection of Duplicate PD Tags. These networks do benefit from the use of LAN Redundancy.

Figure 43 represents a dual local area network. The topology of two local area networks is restricted to be within the HSE Subnet. It is not required that they be identical. LAN A is constructed by connecting interface A of all devices to the LAN media. Similarly, LAN B is constructed by connecting interface B of all devices to it. There is no connectivity between the LANs. The figure does include a device with a single interface. Examples are hand-held calibrators or commercial workstations. Such devices are able to communicate only with devices connected to the LAN to which their interface is connected. Therefore, in the presence of one or more

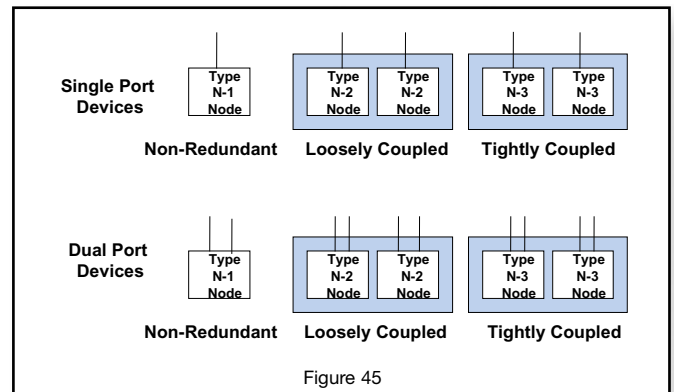
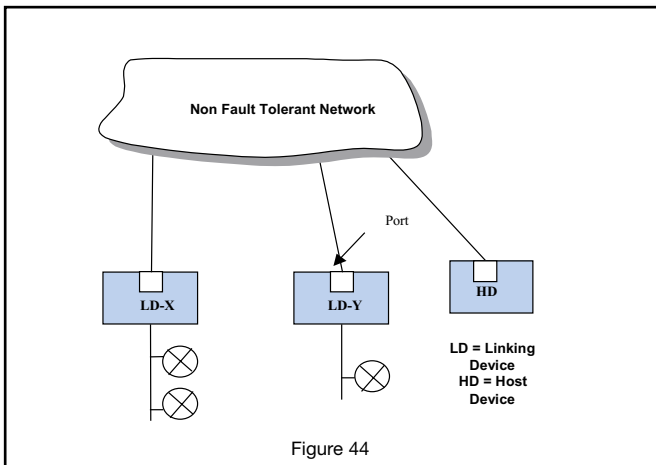



faults, they may not be able to communicate with all other devices on the Dual LAN.

Figure 42 illustrates this type of network. The local area network topology is not restricted. The distinguishing characteristic is that the network has some degree of fault tolerance, but behaves as a single network. The figure includes a device with a single interface. Examples are hand-held calibrators or commercial workstations. Such devices are able to communicate with all other devices connected to the LAN.

4.0 SYSTEM CONFIGURATION

Fieldbus system configuration consists of two phases:
1) System Design and 2) Device Configuration.

4.1 System Design

The system design for fieldbus-based systems is very similar to today's Distributed Control System (DCS) design with the following differences. The first difference is in the physical wiring due to the change from 4-20 mA analog point-to-point wiring to a digital bus wiring where many devices can be connected to one wire.

Each device on the fieldbus must have a unique physical device tag and a corresponding network address.

The second difference is the ability to distribute the control and input/output (I/O) subsystem functions from the control system to the fieldbus devices. This may reduce the number of rack mounted controllers and remote mounted I/O equipment needed for the system design (Figure 46).

4.2 Device Configuration

After the system design is completed and the instruments have been selected, the device configuration is performed by connecting Function Block inputs and outputs together in each device as required by the control strategy (Figure 47).

After all of the function block connections and other configuration items such as device names, loop tags, and loop execution rate have been entered, the configuration device generates information for each fieldbus device.

A stand-alone loop can be configured if there is a field device that is a Link Master. This will allow continued operation of the loop without the configuration device or a central console (Figure 48).

The system becomes operational after the fieldbus devices have received their configurations.

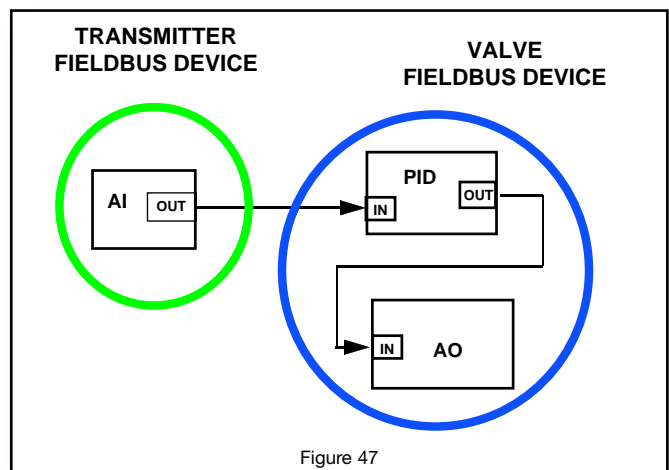
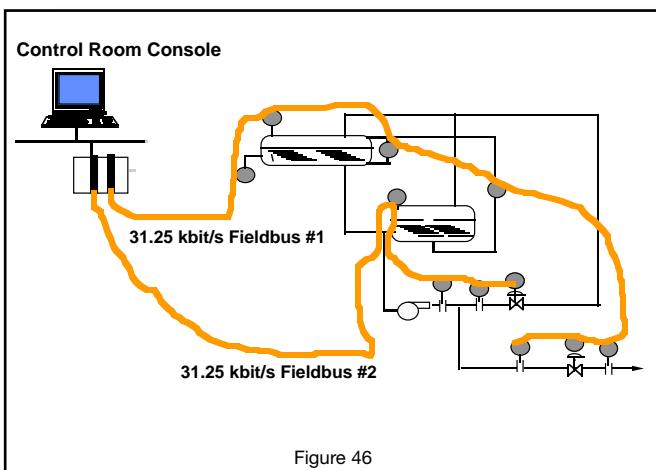

5.0 FIELD TEST SYSTEM

Benefits of fieldbus technology were directly observed during field tests on real processes. This section gives the results of one of the tests. Fieldbus devices were installed on a condensate recovery system in a utilities plant.

The recovery system receives the steam condensate returning to the utilities plant from the rest of the site and returns this condensate into the water treatment system (Figure 49).

The process consists of two tanks: a flash tank, which is approximately 85 gallons and a condensate tank of approximately 20 gallons. The flash tank is mounted directly above the other tank.

The returning condensate flows into the flash tank, where lowering of pressure may cause the condensate to flash to steam. The liquid condensate flows down into the condensate tank from which it is pumped forward into the boiler feedwater system.

5.1 Test Instrumentation

Fieldbus transmitter instrumentation installed on the system included:

- level on each tank and across both tanks
- pressure on the flash tank
- flow on the boiler feedwater system
- total pump flow
- recycle flow

The control valves were equipped with digital positioners which were used to control the boiler feedwater treatment and recycle flow.

The instruments were connected to one of two fieldbuses connected to a DCS located in the utilities control room. The installation used a combination of existing twisted pair wiring and new wiring. While not required by the process, intrinsic safety barriers were demonstrated on the system.

Performance of the fieldbus was monitored by bus analyzers.

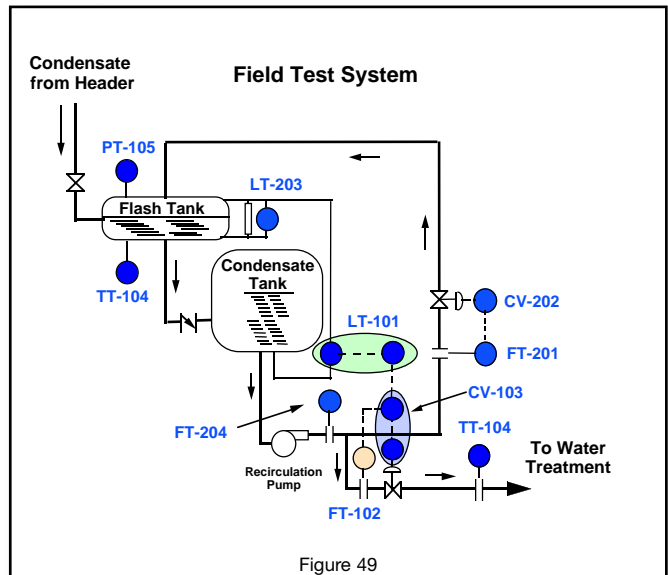
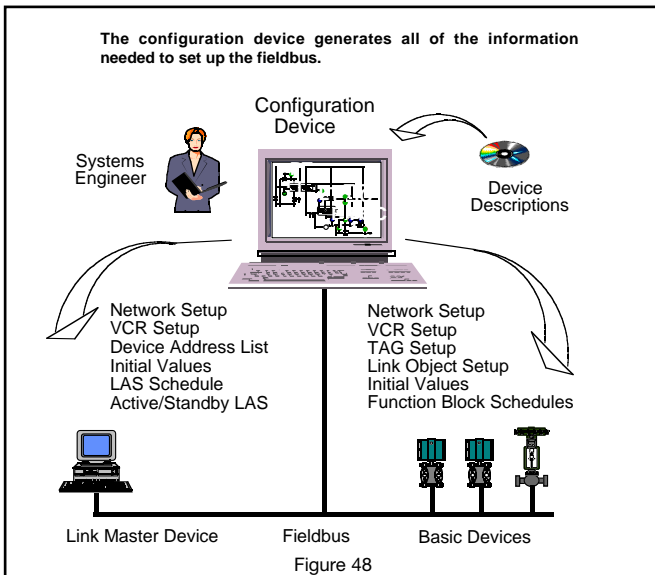

Wiring was configured by connecting the fieldbus devices to one of two terminal panels in a junction box located by the process equipment. Two wire pairs, one pair for each terminal panel, were used to connect the fieldbuses to the control room.

The total condensate level of the system is controlled by selecting a preferred setpoint on the level PID, LIC-101, which is located in the level transmitter. The level PID is used as the primary loop cascaded to the flow PID, FIC-103, located in the valve on the feedwater system.

The re-circulation of condensate, from the condensate tank to the flash tank, is controlled by an additional PID loop, FIC-202, located in the valve. The control strategy for this cascade loop is totally implemented in the transmitters and flow valve as shown in Figure 50.

5.2 Installation, Startup, and Operation Benefits Observed

The wire runs, from fieldbus devices to the terminal panel, averaged 28 meters of new wire for each device, while two 185 meters of existing wire runs were used from each of the terminal panels to the control room.

If standard 4-20 mA analog devices had been used, ten new runs of 230 meters (28 meters from the device to the terminal panel plus 185 meters to the equipment room plus 17 meters to the DCS) would have been required. Savings in installation costs are summarized in the following table.

Wiring Technology	Wire Length	Number of Screw Terminations
4-20 mA Analog	2300 meters	120
Digital Fieldbus	510 meters	46
Savings with Fieldbus	1790 meters	74
Savings in %	78%	62%

The reduction of interface cards (by 50%), equipment cabinet space (caused by a reduction in the number of I/O interfaces), and the elimination of termination panels resulted in a 46% reduction in equipment costs.

Some applications might specify fewer devices per wire pair than the test system. In that case, the savings shown in the above table would be proportionately reduced according to the specific wiring configuration.

During the checkout phase, a reduction in effort to confirm the proper connection of the fieldbus devices was observed. One person performed the checkout by using the test tool connected to the fieldbus. With conventional 4-20 mA wiring, two people would have been required to check out each wire and confirm operation of each transmitter.

Each transmitter was interrogated and adjusted remotely. Device parameters such as the high and low range values were changed without having a technician adjust a potentiometer in the field.

When a device was disconnected from the fieldbus, the disconnection did not affect any other devices remaining on the bus. When the device was reconnected, the system had no trouble re-establishing communication with the device. Approximately two person-days of labor (25%) were saved due to the remote verification of wiring, remote device identification, and remote device configuration checkout.

The processing load on the DCS controller was reduced because of the PID algorithms which were executing in the fieldbus devices.

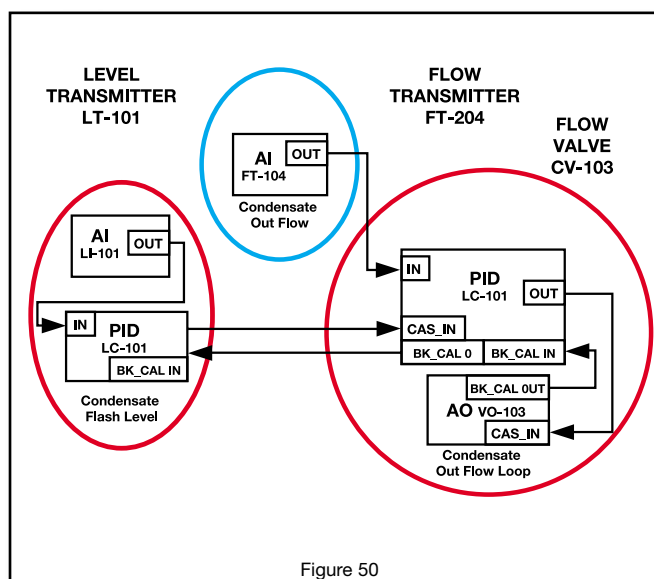

Figure 50

6.0 FEATURES SUMMARY

FOUNDATION fieldbus technology is already changing the way systems perform control and will have an even greater impact on system architecture, interoperability and openness than the H1 technology.

FOUNDATION fieldbus tightly integrates system components, making field instruments an integral part of the system just like the controls (i.e., field instruments and “system” are not two separate islands). The operator workstations and interfaces are referred to as the “host” of the system. Whereas, FOUNDATION H1 fieldbus technology is used at the field device level making such devices as transmitters and positioners interoperable, the FOUNDATION HSE fieldbus technology is used at a higher level in the system hierarchy, where host devices and subsystems are networked. The capabilities of HSE go far beyond that of traditional remote-I/O and control-level networks.

A Linking Device is used to interconnect 31.25 kbit/s fieldbuses and make them accessible to an HSE backbone running at 100 Mbit/s or 1Gbit/s

(Figure 51). The I/O Subsystem Interface shown in the figure allows other networks such as DeviceNet® and Profibus® to be mapped into standard FOUNDATION fieldbus function blocks. The I/O Subsystem Interface can be connected to the 31.25 kbit/s fieldbus or HSE.

Since all of the 31.25 kbit/s FOUNDATION fieldbus messages are communicated on the HSE using standard Ethernet protocols (e.g. TCP/IP, SNMP, etc.), commercial off-the-shelf HSE equipment such as Switches and Routers are used to create larger networks (Figure 52). Of course all or part of the HSE network can be made redundant to achieve the level fault tolerance needed by the application.

In the control system architecture H1 fieldbus is used at the field-level to connect transmitters and positioners etc. HSE is used at a higher level between linking devices and the host workstations (i.e., HSE will not replace H1, but the two complement each other and serve enterprise needs at different levels of the plant hierarchy).

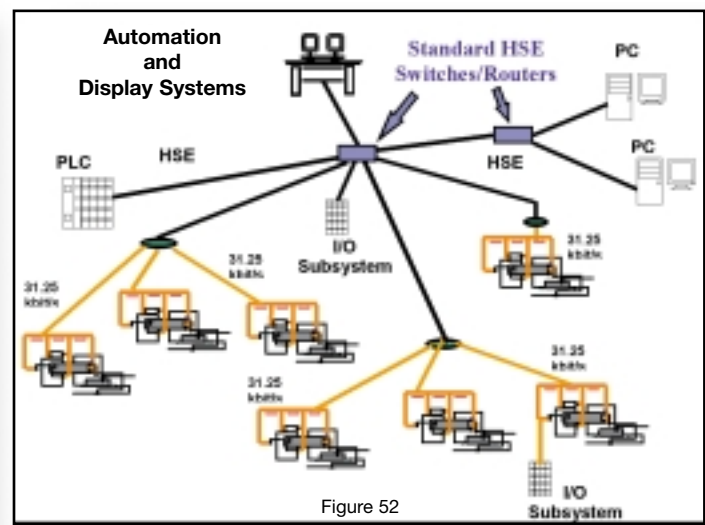
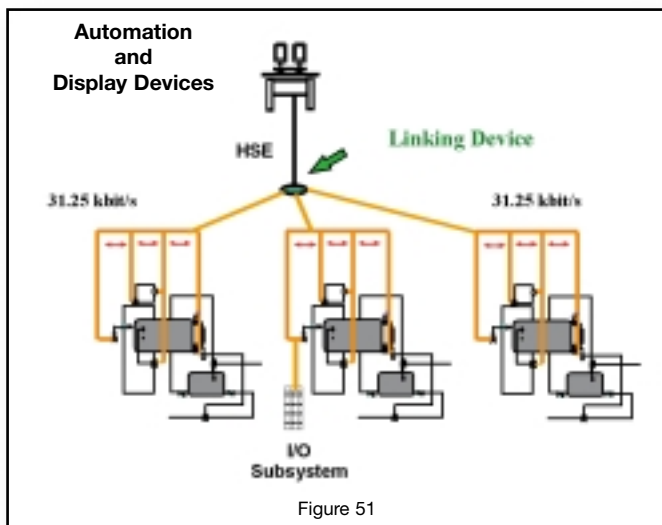

	H1	HSE
Speed	31.25 kbit/s	100 Mbit/s
Distance (per segment)	1900 m	100 m
Two-wire	Yes	No
Multidrop	Yes	No
Bus power	Yes	No
Intrinsically safe	Yes	No
Redundancy	No	Yes
Deterministic	Yes	Yes

Ethernet is limited to 100 m, which is too short for wiring the instruments in the field. Ethernet needs hubs and multi-core cable that although cheap, would be too costly and space consuming. Ethernet provides no power so additional wires are needed. Ethernet is not intrinsically safe so it could not be used in hazardous areas such as those found in the chemical and petrochemical industry. Likewise, H1 has too low bandwidth to be used as backbone for the entire plant, and does not have redundancy making it unwise to make more than a few loops depend on each network. Thus the two complement each other perfectly.

Features Summary



Standard Function Blocks Running in Field Devices	Distributed Control on a COTS 100 Megabit per Second Backbone
Single-loop Integrity – Control in Field – Increased Loop Performance	Same Function Blocks and Device Description Technology on H1
Reduces Traffic/Load on the Central Control System	Function Block Synchronization on the Backbone
More Information for Operators – Including Signal Status	System Time Synchronization – Master Clock (e.g., GPS) to HSE to H1
Increases Measurement Accuracy – Reduces A/D Conversions – Supports All Digital Sensor Integration	New Flexible Function Blocks for Hybrid/Batch/PLC/Remote I/O Applications
Fault Tolerant – Supports Multiple Link Masters and Time Masters	Supports High Speed Data Generators/Users (e.g., Analyzers, Controllers)
Reduces Wiring, Cabinets, Power Supplies, and Equipment Room Size	Uses Standard Internet DHCP – Address Lease Reuse Reduces Startup Time
Increases Uptime Due to Better Remote Diagnostics and Less Equipment	Short Messages Can Be Packed to Reduce Interrupts on Receiving CPUs
	Provides Redundant Network Interface and Redundant Devices.

H1 and HSE Designed for Maximum Flexibility

H1	HSE
Modern, All-Digital Network – Intelligent Instrumentation	Annunciation Contains Manufacturer Identification and Model Number
Power and Signal on a Single, Multi-Drop Wire Pair	Network Independence – Supports Dual LAN and Ring Topologies
Distances up to 1,900 Meters – Can Add Repeaters, Fiber Option	Isolated Subnet, Backbone, Device and Subsystem Integration
Bus, Star and Tree Wiring Topologies	Built-in Diagnostics – Annunciation of Changes and Network Statistics
Automatic Device Assignment – No Need for Switches on the Device	Annunciation Contains Manufacturer Identification and Model Number
Supports Intrinsic Safety, Multiple Devices on an I.S. Barrier	Network Independence - Supports Dual LAN and Ring Topologies
Remote Configuration & Diagnostics, Easy Evolution Due to Function Blocks.	Isolated Subnet, Backbone, Device and Subsystem Integration
	Built-in Diagnostics – Annunciation of Changes and Network Statistics

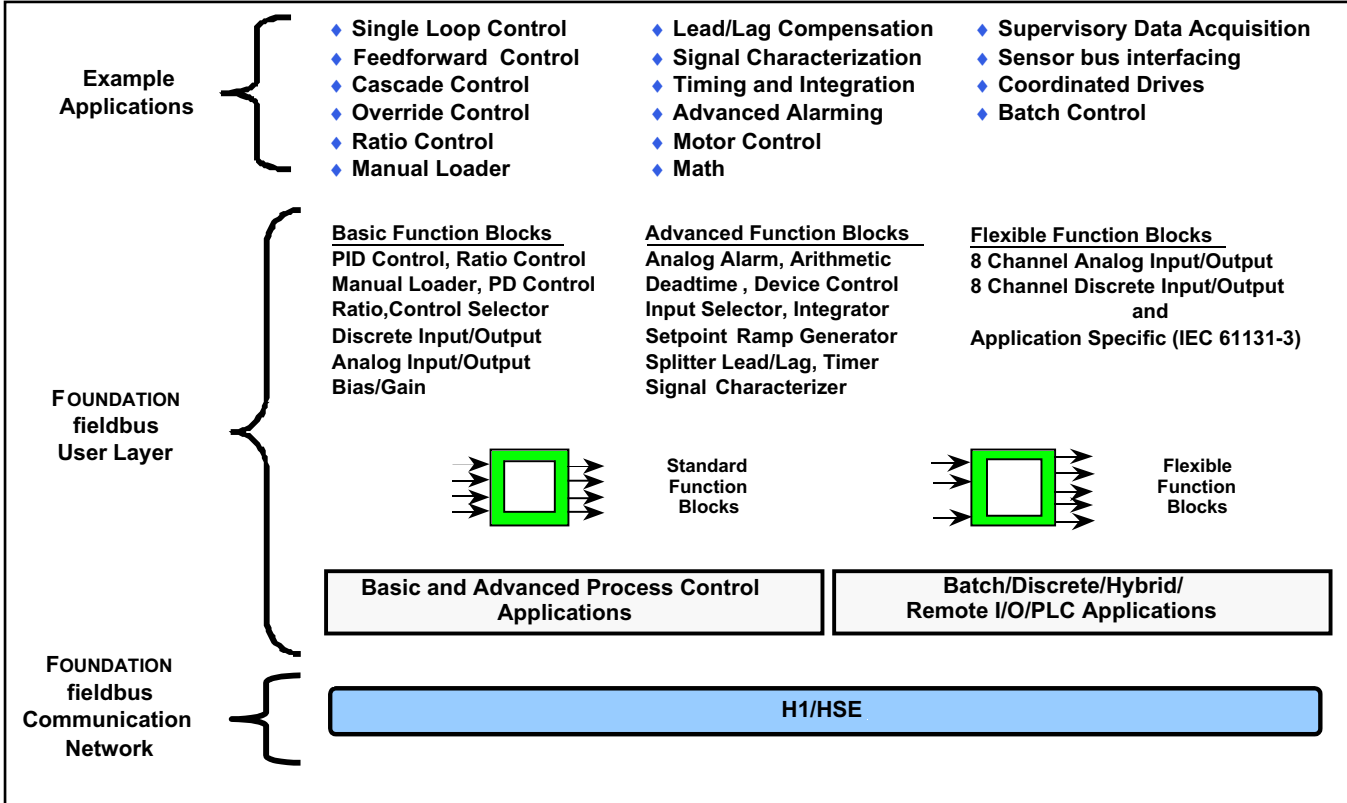

7.0 REFERENCES

1. Fieldbus Standard for Use in Industrial Control Systems, ISA S50.02.
2. Fieldbus Standard for Use in Industrial Control Systems, IEC 61158:2000 (ED 2.0).
3. FOUNDATION Fieldbus Specifications, Fieldbus Foundation, 1994-1998.
4. Benefits Observed During Field Trials Of An Interoperable Fieldbus, Kurt A. Zech, Fieldbus Foundation, Paper #94-504 — ISA, 1994.
5. Abstract Syntax Notation One (ASN.1). The Tutorial and Reference, Douglas Steedman, Technology Appraisals Ltd., 1993, ISBN 1 871802 06 7.

8.0 DOCUMENT LIST

The following documents are part of the Fieldbus Foundation products and specifications.

Application Guides (available at www.fieldbus.org)

- AG-140 31.25 kbit/s Wiring and Installation Guide
- AG-163 31.25 kbit/s Intrinsically Safe Systems Application Guide
- AG-165 Fieldbus Installation and Planning Guide

FF-007: H1, HSE and User Layer Technical Specifications

- FF-103 Common File Format
- FF-131 Standard Tables
- FF-593 High Speed Ethernet Redundancy
- FF-581 System Architecture
- FF-586 Ethernet Presence
- FF-588 Field Device Access (FDA) Agent
- FF-589 HSE System Management
- FF-801 Network Management Specification
- FF-803 HSE Network Management
- FF-806 Data Link Protocol Specification Bridge Operation Addendum
- FF-816 31.25 kbit/s Physical Layer Profile Specification
- FF-821 Data Link Layer Services Subset Specification
- FF-822 Data Link Layer Protocol Specification
- FF-880 System Management Specification
- FF-870 Fieldbus Message Specification
- FF-875 Fieldbus Access Sublayer Specification

- FF-890 Function Block Application Process - Part 1
- FF-891 Function Block Application Process - Part 2
- FF-892 Function Block Application Process - Part 3
- FF-893 Function Block Application Process - Part 4
- FF-894 Function Block Application Process - Part 5
- FF-900 Device Description Language Specification
- FF-940 31.25 kbit/s Communication Profile
- FF-941 HSE Communication Profile

Preliminary Specifications (Available to members only)

- FF-902 Transducer Block Application Process - Part 1
- FF-903 Transducer Block Application Process - Part 2

AT-400 Tokenizer Kit

- FD-100 DDL Tokenizer User's Manual

AT-401 DD Services Kit

- FD-110 DDS User's Guide

AT-410 Conformance Test Kit

- FD-200 Conformance Tester User's Guide

AT-420 Interoperability Test Kit

- FD-210 Interoperability Tester User's Guide

Tech Notes

- TN-003 Tech Note 3
- Additional Tech Notes at www.fieldbus.org (members only)

9.0 ACRONYM TABLE

ASN.1	Abstract Syntax Notation 1	kbit/s	kilobits per second
CCITT	International Telegraph and Telephone Consultative Committee	kHz	kilohertz
CD	Compel Data	LAN	Local Area Network
CFF	Common File Format	LAS	Link Active Scheduler
DC	Direct Current	LRE	LAN Redundancy Entity
DCS	Distributed Control System	mA	Milliampere
DD	Device Description	Mbit/s	Megabits per second
DDL	Device Description Language	NMIB	Network Management Information Database
DDS	Device Description Services	MVC	Multi-Variable Container
DHCP	Dynamic Host Configuration Protocol	OD	Object Dictionary
DLL	Data Link Layer	OSI	Open Systems Interconnect
EUC	End User Council	PC	Personal Computer
FAS	Fieldbus Access Sublayer	PDU	Protocol Data Unit
FCS	Frame Check Sequence	PHY	Physical Layer
FB	Function Block	PID	Proportional, Integral, Derivative
FF	Fieldbus Foundation	PN	Probe Node
FMS	Fieldbus Message Specification	PT	Pass Token
HIST	Host Interoperability Support Test	SM	System Management
HSE	High Speed Ethernet	SMIB	System Management Information Base
Gbit/s	Gigabits per second	SNMP	Simple Network Management Protocol
IEC	International Electrotechnical Commission	SNTP	Simple Network Time Protocol
IP	Internet Protocol	TCP/IP	Transport Control Protocol/Internet Protocol
I.S.	Intrinsically Safe	TD	Time Distribution
ISA	The International Society for Measurement and Control	UDP	User Datagram Protocol
ISO	International Organization of Standards	VFD	Virtual Field Device
		VCR	Virtual Communication Relationship

10.0 TERMINOLOGY

Network: (Fieldbus) All of the media, connectors, and associated communication elements by which a given set of communicating devices are interconnected. ISA S50 (IEC 61158-2:2000 (ed. 2.0), fieldbus standard for use in industrial control systems — Part 2: Physical Layer specification and service definition)

Segment: The section of a fieldbus that is terminated in its characteristic impedance. Segments are linked by repeaters to form a complete fieldbus (network). ISA S50 (IEC 61158-2:2000 (ed. 2.0), fieldbus standard for use in industrial control systems — Part 2: Physical Layer specification and service definition)